

# STÛV 30 COMPACT: MODEL SPECIFICATIONS

---

|                     |    |
|---------------------|----|
| 1. TECHNICAL DATA   | 2  |
| 2. PRE-INSTALLATION | 3  |
| 3. INSTALLATION     | 5  |
| 4. OPERATION        | 9  |
| 5. TESTING          | 10 |

---

Keep for future use

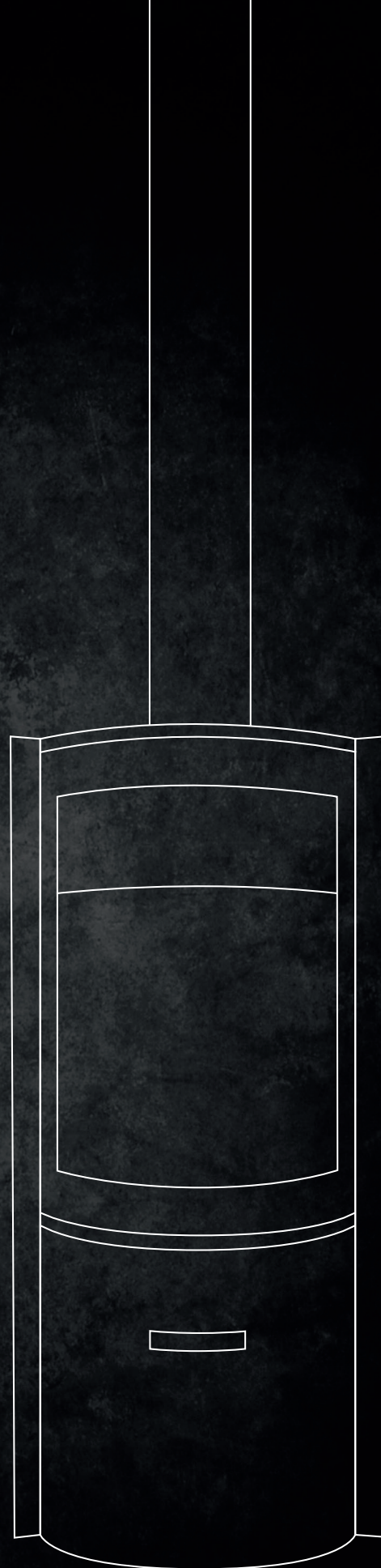

**stûv**  
LE FEU ESSENTIEL

**obliqa**

**WEIGHT AND DIMENSIONS:**

|                    |                       |
|--------------------|-----------------------|
| Dimensions Firebox | W465 x H1040 x D447mm |
| Firebox weight     | 114kg                 |
| Flue kit           | Standard 6"/8"/10"    |

**DETERMINED UNDER TEST CONDITIONS:**

|                              |          |
|------------------------------|----------|
| Nominal thermal output       | 8kW      |
| Efficiency (Australian Test) | 61%      |
| Emissions (Australian Test)  | 1.3 g/Kg |

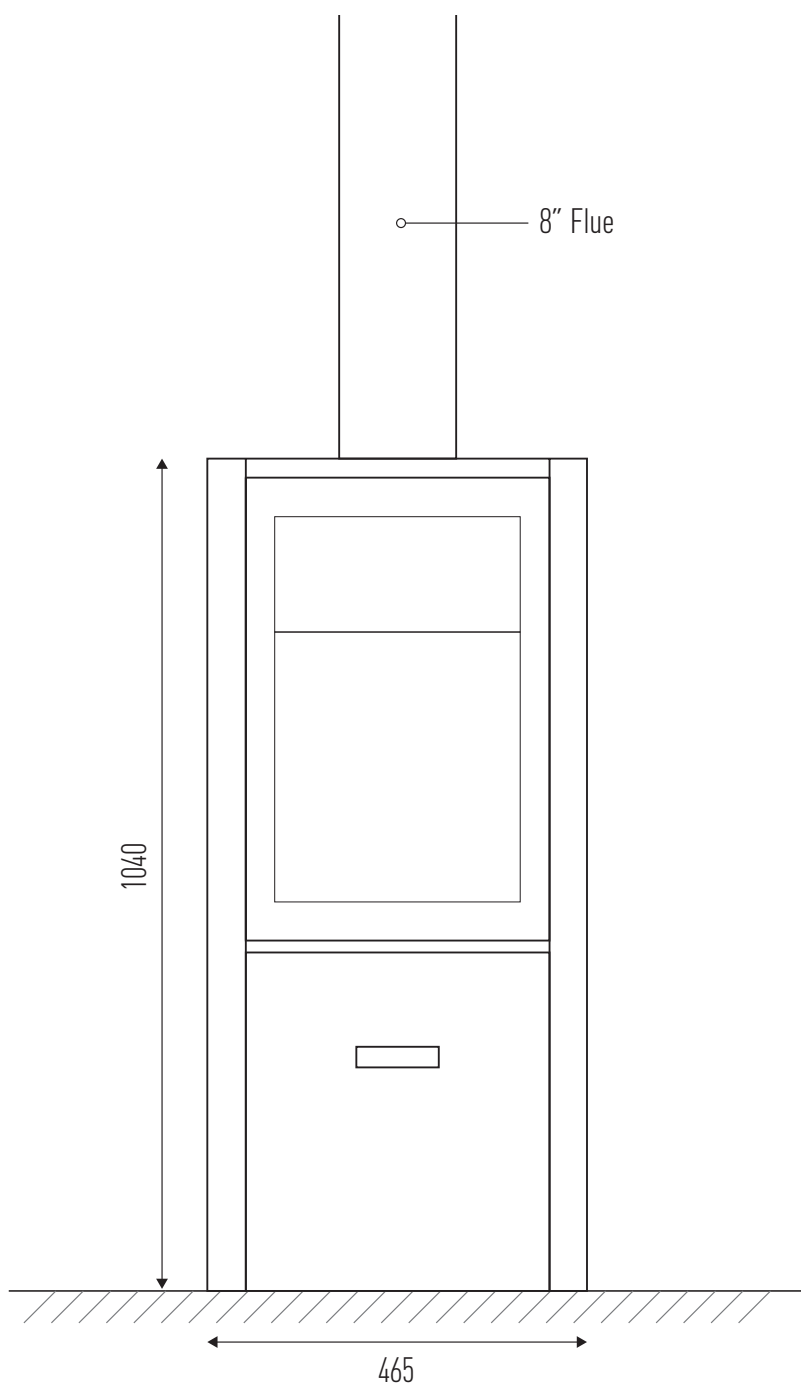

Congratulations on your purchase of the STÔV 30 Compact. This appliance should be installed and checked by a qualified professional. Ensure you have read the operation guidelines thoroughly prior to first use. For any questions or concerns please contact Oblica on 03 9416 0400.

The installation process is outlined below:

- Determine position of firebox and flue carefully observing the clearances described within this section
- Install the external flue
- Install the internal flue and engage the firebox
- Ensure the floor has adequate protection

### **CAUTION:**

Using components or parts other than those provided by the manufacturer or modifying the specification of components may result in inferior or unsafe operation. If such action is necessary, consult the manufacturer in the first instance.

### **WARNING:**

- **The appliance and flue-system must be installed in accordance with AS/NZS 2918 and the relevant building code or codes.**
- **Any modification of the appliance that has not been approved in writing by the testing authority will be in breach of the approval granted for compliance with AS/NZS 4013.**
- **Once the flue has been installed and approved by a professional installer, the flue must not be modified in any way.**

# MINIMUM CLEARANCE – INTERNAL

## 2.1 Clearance from non-combustible surfaces (eg masonry)

100mm minimum clearance is required from fully non-combustible surfaces.

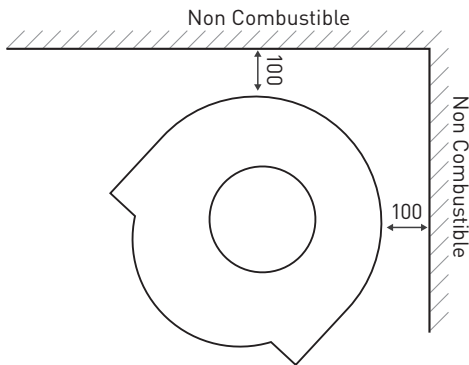

## 2.2 Clearance from glass

250mm minimum clearance is required from normal non-combustible glass.

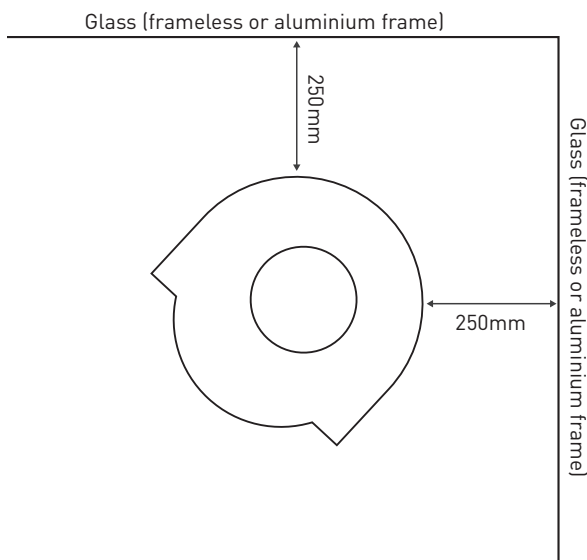

### IMPORTANT:

Frames must also be considered. Timber window frames must be treated as combustible surfaces (see 2.3). Aluminium frames can be treated as non-combustible surfaces (see 2.2).

## 2.3 Clearance from combustible surfaces (eg timber joist & concrete)

Clearances may be reduced with the application of heat shielding to walls in accordance to the Australian Building Code.

For information on heat shielding please contact our office on 03 9416 0400 or email [info@oblica.com.au](mailto:info@oblica.com.au).

### Configuration 1 – Parallel installation

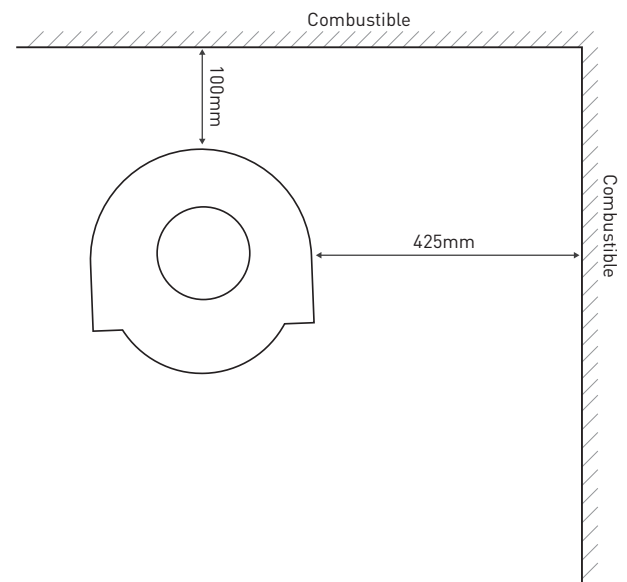

### Configuration 2 – Corner installation

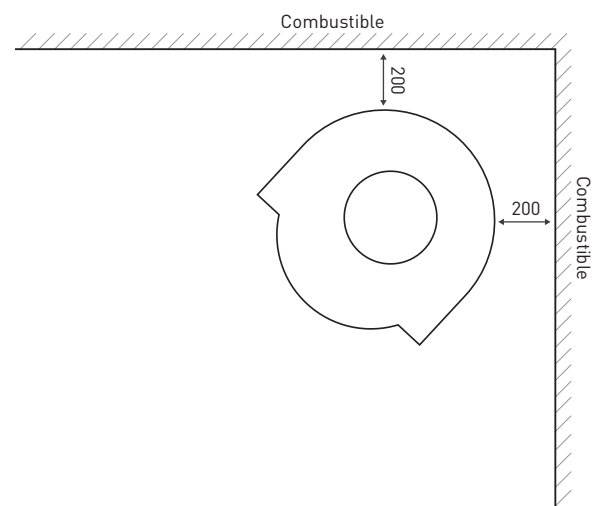

### 3.1 Installing flue kit

Ensure flue is installed as per Australian standards (see the following diagrams below).

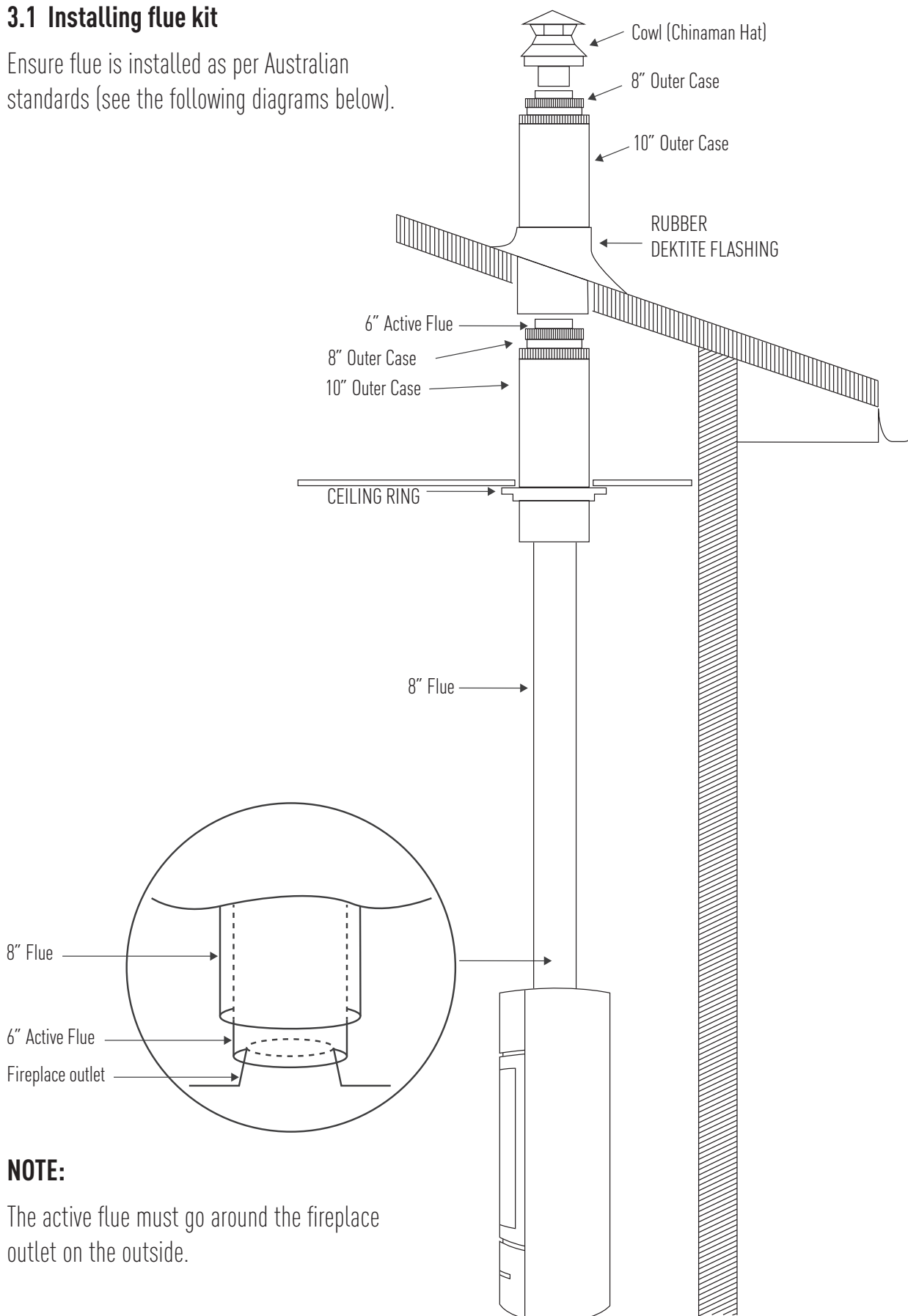

**NOTE:**

The active flue must go around the fireplace outlet on the outside.

## PITCHED ROOF INSTALLATION

The top of the flue must be 400mm higher than the highest point of the roof. Alternatively, there must be a minimum distance of 3 meters from any higher section of roof.

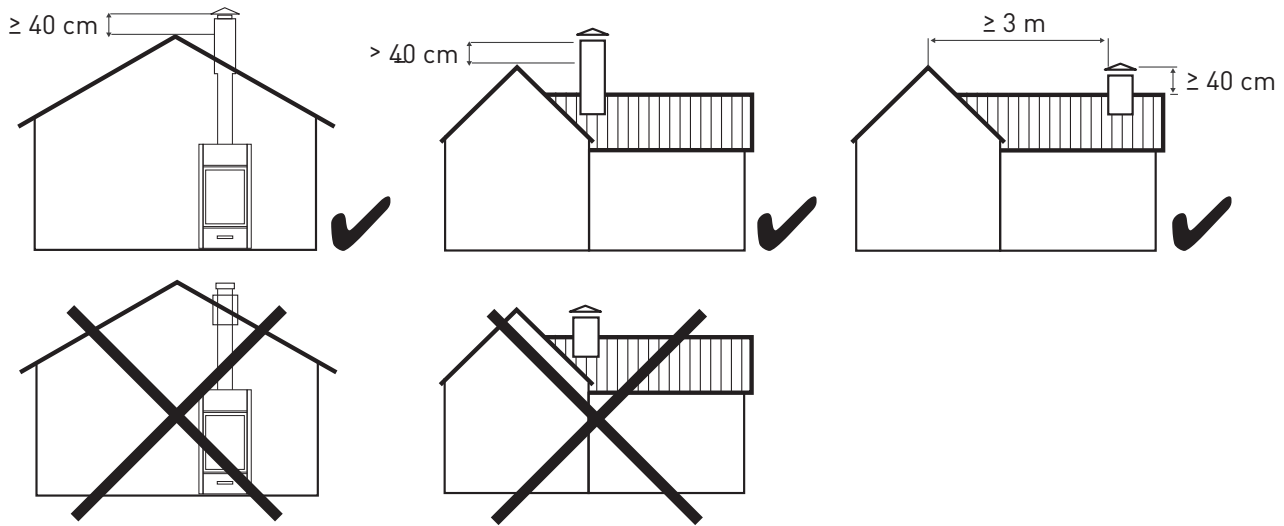

## FLAT ROOF INSTALLATION (LESS THAN 5° PITCH)

The top of the flue must be 900mm above the roofline. Alternatively, there must be a minimum distance of 3 meters from any higher section of roof.

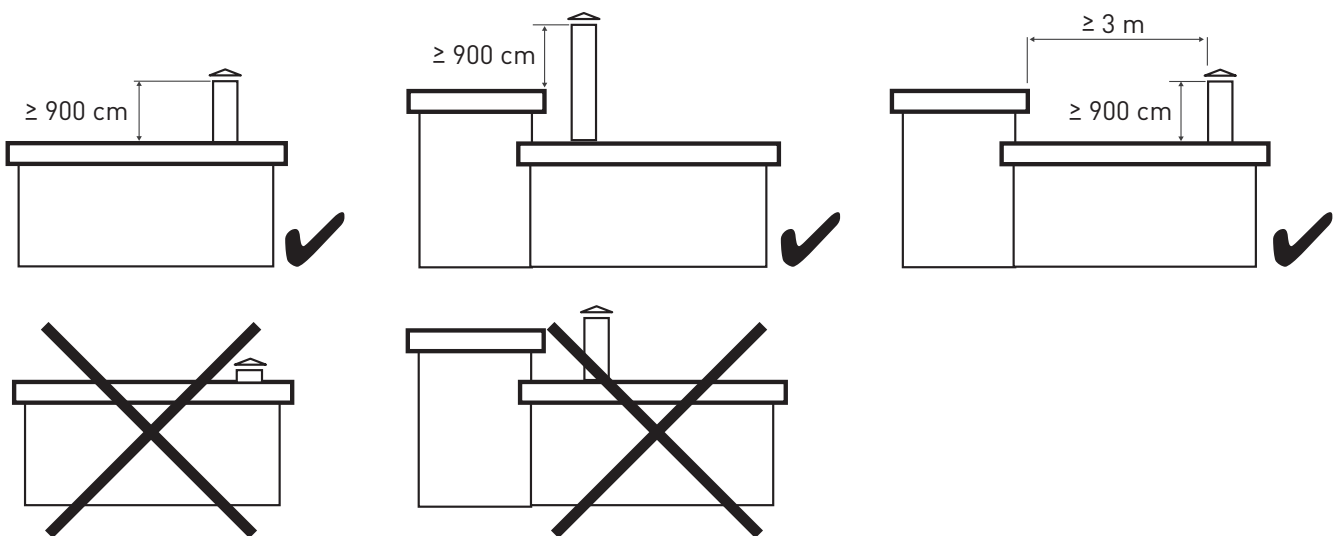

### 3.2 Protecting the floor

- Any combustible floor beneath a fireplace must have a floor protector that extends 300mm at the front.
- If installed directly on combustible material, the floor protector must be made of a minimum 6mm thick cement sheet. Non-combustible finishes can be applied to the floor protector (tiles, steel sheet, light concrete, etc).
- If the combustible floor is installed on concrete, you can replace the combustible material with non-combustible material laid directly onto the concrete.

#### FLOOR PROTECTOR LAID ON TIMBER FLOOR

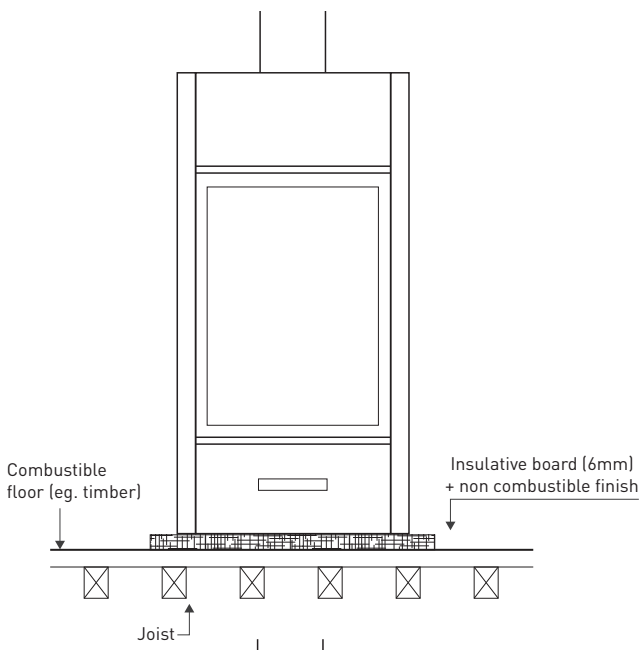

#### FLOOR PROTECTOR LAID ON JOIST

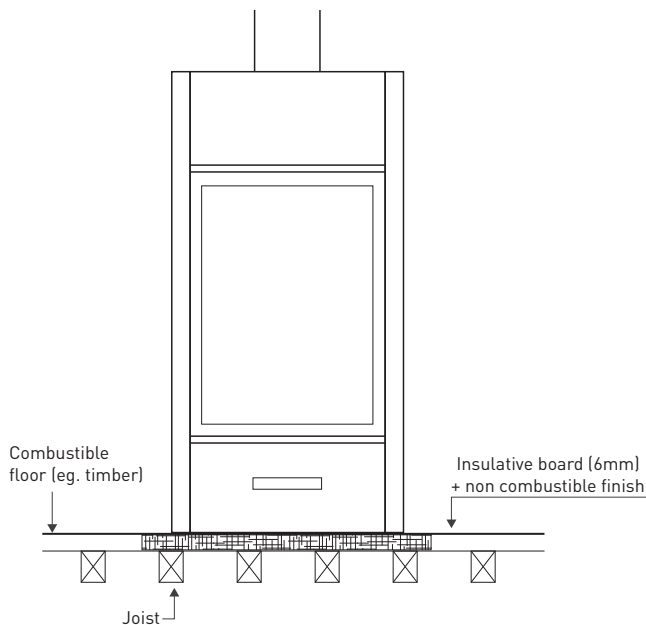

## FLOOR PROTECTOR LAID ON CONCRETE

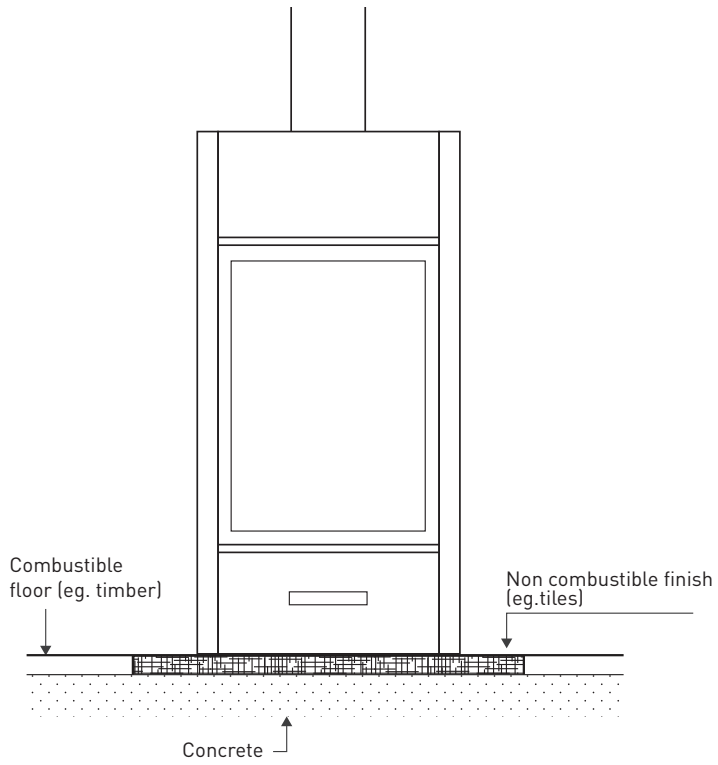

## TOP VIEW

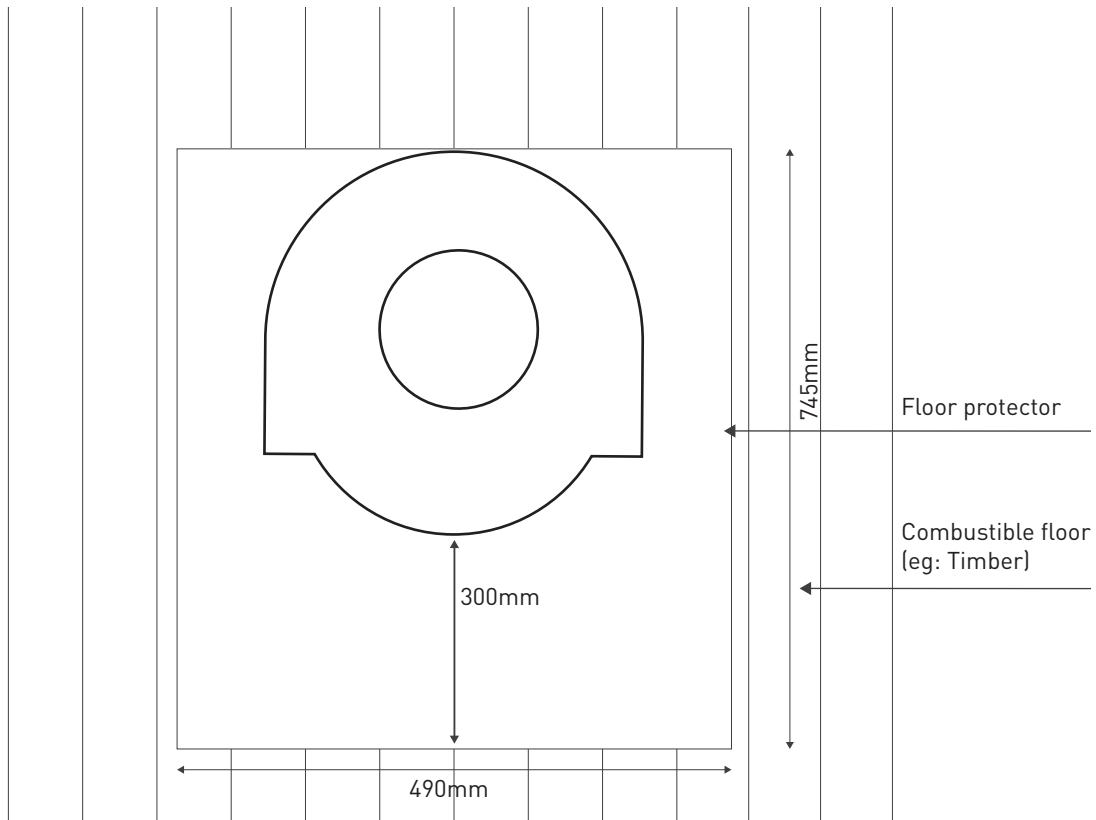



## 4.1 What you should burn

- Untreated, air dried hardwood
- Split logs with a humidity content of less than 20%

## 4.2 Do not burn

- Trash
- Painted plastic
- Coated or preservative treated wood
- Waste or black coal
- Inflammable liquids
- Fire gels
- Moist wood with a residual humidity content of more than 20% (this may cause soot of the chimney).

### **IMPORTANT:**

- Misuse may lead to unhealthy and environmentally harmful emissions and will void any warranty or guarantee.
- The maximum load capacity for the STÔV 30 Compact is 5kg of wood.
- Burning only seasoned hardwood helps to protect the environment and lower emissions.

For details of a wood supplier in your area please call our office on 03 9416 0400 or email [info@oblica.com.au](mailto:info@oblica.com.au).

### **WARNING:**

- **Do not use flammable liquids or aerosols to start or rekindle the fire.**
- **Do not use flammable liquids or aerosols in the vicinity of the fireplace when operating.**
- **Do not store fuel within prescribed installation clearance distances.**
- **The use of some types of preservative-treated woods as a fuel can be hazardous.**

**TEST REPORT NO****ASFT21071-1****TESTING LABORATORY:**

Australian Solid Fuel Testing

**MANUFACTURER:**

STÔV

**MODEL:**

STÔV 30 Compact

**WORK REQUESTED:**

Assessment of appliance to AS/NZS 4012:2014 for determination of Power Output and Efficiency and AS/NZS 4013:2014 for Flue Gas Emission using hardwood fuel.

**ISSUE DATE:**

28/09/2021

**INVESTIGATING OFFICER:**

Steve Marland

**RESULTS:**

The appliance particulate emission factor established in testing is 1.3g/kg of dry wood, within the maximum specification of 2.5g/kg of dry wood and an efficiency of 61%.

**CONCLUSION:**

This appliance does comply with the requirements of AS/NZS 4012:4013 (2014) for the configuration tested.