

ORTAL[®]
YOUR LIFE. YOUR FIRE.

Installation and Operation Manual – AU/NZ Wilderness Models



ORTAL Heating Systems Ltd.

**“The appliance must be installed according to
AS/NZS 5601.1 (latest edition).”**

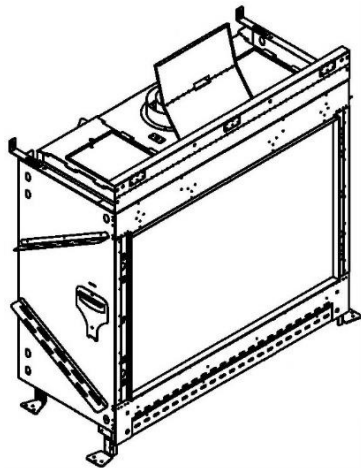

ORTAL Heating Solutions Ltd.

INSTALLATION & OPERATION MANUAL



SAVE THESE INSTRUCTIONS

Make yourself fully aware of all the following instructions and the many features of the Ortal room sealed gas fireplace appliance. **DO NOT DISCARD THIS MANUAL!**

! DANGER



HOT GLASS WILL CAUSE BURNS

DO NOT TOUCH GLASS UNTIL COOLED

NEVER ALLOW CHILDREN TO TOUCH GLASS

A barrier designed to reduce the risk of burns from the hot viewing glass is provided with this appliance and shall be installed for the protection of children and other at-risk individuals.

WARNING:

FIRE OR EXPLOSION HAZARD

Failure to follow safety warnings exactly, could result in serious injury, death, or property damage.

Installation and service must be performed by a qualified/authorized installer, service agency, or the gas supplier. INSTALLER: test the operation of the appliance before leaving.

DANGER: IF YOU SMELL GAS

- Do not try to light any appliance.
- Do not touch any electrical switch; do not use any phone in your building.
- Leave the building immediately.
- Immediately call you gas supplier from a neighbor's phone. Follow the gas supplier's instructions.
- If you cannot reach your gas supplier, call the fire department.

DO NOT PLACE ARTICLES ON OR AGAINST THIS APPLIANCE.

DO NOT USE OR STORE GASOLINE OR OTHER FLAMMABLE VAPORS AND LIQUIDS IN THE VICINITY OF THIS OR ANY OTHER APPLIANCE.

DO NOT SPRAY AEROSOLS NEAR THIS APPLIANCE WHILE IT IS IN OPERATION.

DO NOT MODIFY THIS APPLIANCE.

Warning: All Wilderness models must be installed with an Ortal Power Flue, using 100/150 concentric flues only.

Testing Standards and Document Information

The ORTAL decorative room sealed gas appliances have been tested and approved by AGA for use with Natural Gas (NG).

Standard references:

- Australian Standard AS/NZS 5601.1 (latest edition - Decorative Gas Log and Other Fuel Effect Appliances)
- Patent Pending for screen barrier glass bracket: USSN 60/040,074



NOTE: Diagrams and illustrations in this manual are not to scale. All fireplace drawings with correct dimensions are available on our website under Products>Downloads>Diagram.



NOTE: For additional details about installing CC units and/or units with Power Flues, please refer to the specific manuals supplied with the product.

Table of Contents

Fireplace Safety Information and Warnings	1
Operating Warnings	3
Certifications and Codes	4
Product List: Models and Burners	5
Prior to Installation.....	6
Locate the Fireplace.....	6
Fireplace Installation	7
First Trip to Site: Planning.....	7
Second Trip to Site: Installation	7
Third Trip to Site: Start-up	8
Post-Installation.....	9
Initial Burning Period	9
Final Inspection Procedure	9
Final Checks and User Instruction.....	9
Building Checklist	10
Framing.....	11
Framing Dimensions	11
Cavity Floor/Platform.....	15
Hearth Extension	15
Viewing Area Clearances	15
Clearance around the flue pipe must be maintained	18
Zero-Clearance Stand-Offs.....	20
Heat Release	23
Air Intake.....	26
Mounting a TV/Artwork.....	28
Flush Mounted TV/Artwork.....	29
Recessed TV/Artwork	30
Access Panel	31
Cavity Area Minimum	31
Recessed Partial Ledge	31
Step-by-Step Cavity Construction.....	33
Cold Climate Insulation	34
Finishing.....	35
Flush Installation	35
Recessed Installation	36
Gas Pressures	37
Routing the Gas Line.....	38
Control Connections	38
Gas and Electrical Components.....	39
Gas Conversion.....	40

Pilot and Thermocouple Maintenance	42
General Flue Requirements.....	43
Power Flue Installation.....	44
Pre installation Considerations	44
Flue Clearances.....	45
Flue Installation and Clearances.....	46
Vertical Clearance Diagram.....	46
Flue Termination Drawings	47
Flue Maintenance.....	48
Chimney Shroud	49
Fireplace Heat Barrier.....	51
Removal / Assembly of the Double Glass Heat Barrier and Inner Glass.....	52
Removing/Assembling the Back Panel	60
75/65 Front Bricks Installation	64
Traditional Bricks Installation	66
Electrical Requirements.....	70
Power Outage	70
Pairing the Remote and Receiver	70
Wiring Diagram.....	71
Home Automation Wiring Diagram.....	72
Interior Design Media.....	73
Media Placement Guidelines	73
Media Setup.....	74
Wilderness Log Sets	74
Log Installation Warnings	75
Driftwood Log Setup.....	77
Operation	89
10-Button Remote Control Handset.....	90
Operating Instructions	90
Wall Switch	92
Operating Instructions	92
General Maintenance.....	94
Appendix A: Fireplace Troubleshooting Guide.....	95
Pre-troubleshooting Checklist	96
Normal Sequence of Fireplace Operation	98
Troubleshooting Pilot Problems	100
Spark But No Pilot	100
No Spark to the Pilot.....	100
Pilot Turns Off After Igniting But Before Burner Turns On	100
Pilot Turns Off After Igniting and After Burner Turns On	101
Troubleshooting Thermocouple Problems.....	102
Checking the Thermocouple	102
Testing the Thermocouple.....	102

Troubleshooting Main Burner Problems	103
Troubleshooting Flame Issues	104
Troubleshooting Beeping	105
Mertik Maxitrol External Source Operation	107
Appendix E: ORTAL Factory Recommended Service Checklist	108
ORTAL Product Service Log.....	109
Appendix F: Warranty Policy	110
Manufacturer Contact Information	113

Table of Figures

Figure 1: Thermocouple Injector.....	42
Figure 2: Double Glass Heat Barrier: Parts	52
Figure 3: Back Panel: Parts	60
Figure 4: Components for Front Bricks Installation.....	64
Figure 5: Components for Traditional Bricks Installation.....	66
Figure 6: ON/OFF and Manual Pilot Valve Switches	96
Figure 7: Valve/Receiver Wires and Interrupter Block.....	97
Figure 8: ORTAL Remote Control	98

Fireplace Safety Information and Warnings

This section provides safety guidelines and instructions. It is important to **SAVE THESE INSTRUCTIONS** and to make yourself fully aware of all the safety protocols and the many features of the ORTAL room sealed gas fireplace appliance.

- **INSTALLER:** Leave this manual with the appliance.
- **OWNER:** Keep this manual for future reference.



NOTE: ALL the warnings and instructions below apply to ALL the models.



WARNING – HEAT BARRIER

A barrier designed to reduce the risk of burns from hot viewing glass is provided with this appliance and shall be installed. If the barrier becomes damaged, the barrier shall be replaced with the manufacturer's barrier for this appliance. Any safety screen, guard, or barrier removed for servicing the appliance must be replaced prior to operating.

THE BARRIER IS FITTED TO THIS APPLIANCE TO REDUCE THE RISK OF FIRE OR INJURY FROM BURNS AND NO PART OF IT SHOULD BE PERMANENTLY REMOVED.

FOR PROTECTION OF YOUNG CHILDREN OR THE INFIRM, A SECONDARY GUARD IS REQUIRED

WARNING – FIREPLACE TEMPERATURE

Due to high temperatures, the appliance should be located out of traffic and away from furniture and draperies.

Children and adults should be alerted to the hazards of high surface temperature and should stay away to avoid burns or clothing ignition.

Clothing or other flammable material should not be placed on or near the appliance.

Young children should be carefully supervised when they are in the same room as the appliance.

Toddlers, young children and others may be susceptible to accidental contact burns. A physical barrier is recommended if there are at-risk individuals in the house. To restrict access to a fireplace or stove, install an adjustable safety gate to keep toddlers, young children and other at-risk individuals out of the room and away from hot surfaces.

WARNING – GLASS HANDLING

The glass must **ONLY** be removed by an authorized installer. The authorized technician should **ONLY** remove the glass with the suction cups supplied by the manufacturer. To prevent damage to the glass edges, lower the glass to rest in a safe place.

Follow these guidelines for glass handling:

- **Step 1:** Prepare a safe place for the glass to rest.
- **Step 2:** Remove the glass using the suction cup.
- **Step 3:** The glass can now be rested safely.

 **WARNING – IF YOU SMELL GAS**

If you smell gas, take the following action immediately:

- Do not try to light any appliance.
- Do not touch any electrical switch.
- Do not use any phone in your building.
- Call your gas supplier from a neighbour's phone, and follow the gas supplier's instructions.
- If you cannot reach your gas supplier, call the fire department.

 **WARNING – INSTALLATION AND OPERATION**

The room sealed system appliance must be installed as an OEM installation in manufactured homes or an aftermarket permanently located, or a mobile home, where not prohibited by local codes.

The appliance must be installed in accordance with the Manufacturer's instructions and the Manufactured Home Construction and Safety Standard.

If the information in these instructions are not followed exactly, a fire or explosion may result, causing property damage, personal injury or loss of life.

Do not store or use gasoline or other flammable vapours and liquids near this appliance.

 **WARNING – INSTALLATION AND SERVICE**

Installation and repairs must be done by an authorized installer service agency or gas supplier. The appliance should be inspected before use and at least annually by a professional service person. More frequent cleaning may be required due to excessive lint from carpeting, bedding material, etc. It is imperative that control apartments, burners and circulating air passageways of the appliance be kept clean.

Any alteration to the product that causes soot or carbon to form and results in damage is not the responsibility of the manufacturer.

 **WARNING – GAS APPLIANCE**

This appliance is for use only with the type of gas indicated on the rating plate. These appliances are not convertible for use with other gases, unless a certified kit is used and the conversion is performed by an authorized technician.

 **WARNING**

- DO NOT USE AN UNLINED MASONRY CHIMNEY AS THE FLUE FOR THIS APPLIANCE
- PRIMARILY A DECORATIVE AND NOT A HEATING APPLIANCE
- THE GUARD IS FITTED TO THIS APPLIANCE TO REDUCE RISK OF FIRE OR INJURY FROM BURNS AND NO PART OF IT SHOULD BE PERMANENTLY REMOVED. FOR PROTECTION OF YOUNG CHILDREN OR THE INFIRM, A SECONDARY GUARD IS REQUIRED.
- THIS APPLIANCE REQUIRES FRESH AIR TO OPERATE SAFELY

 **WARNING: DO NOT USE AN UNLINED MASONRY CHIMNEY AS THE FLUE FOR THIS APPLIANCE**

Operating Warnings

ORTAL room sealed gas fireplace heaters are sealed combustion, air-circulating gas fireplaces designed for residential applications.

For your safety, please read the following warnings carefully before lighting your fireplace. If you do not follow these instructions exactly, a fire or explosion may result, causing property damage, personal injury or loss of life.

 **WARNING –DO NOT OPERATE YOUR APPLIANCE IF:**

- The glass is NOT properly secured in place
- Connection points are not sealed (for appliances with glass-to-glass connections)
- Glass is cracked
- You smell gas
- Any part of the appliance has been under water
- You have any doubt about safe operation of the unit

If any part has been under water, do not use the appliance. Immediately call an authorized, professional service technician to inspect the appliance and to replace any parts of the control system and any gas controls, which have been under water.

Certifications and Codes

The appliance has been certified for use with either natural gas (NG) or Universal LPG, and **NOT** for use with solid fuels.

These gas fireplace appliances are AGA certified and approved for indoor use. They can be specialized with certain requirements for indoor-outdoor use (i.e., tunnel models). For indoor installation, they must be installed while maintaining required clearances. Installation is recommended in living spaces such as bedrooms, living rooms, great rooms, etc. The appliance is not approved for closet installation.

The appliance must be installed according to ORTAL requirements in addition to any local codes that may apply. The appliance must be properly connected to an approved flueing system. Refer to the specific appliance to determine flue size and pathway requirements. In addition, adhere to the following pre-installation guidelines:

- Approved flue system manufacturers are:
 - DuraVent
- Consult the authority having jurisdiction to determine the need for a permit **PRIOR** to starting the installation.
- It is the responsibility of the installer to ensure that this fireplace is installed in compliance with the manufacturer's instructions and all the applicable codes.
- Before starting, take careful note of **ALL** the **WARNINGS** in this manual.

Product List: Models and Burners

The following table lists burners and flueing for models using the installation codes for decorative flued gas fireplaces. Adaptors are not required.

MODELS: FR/RS/LS/TS/SA/TU/H/HH/TR		
Models	Wilderness 90-110-130-150-170-200 H/HH-FR/RS/LS/TS/TR/SA	
Gas	NG	Propane
Burner	Wilderness 70-3	
Injectors	Left log – 800 Middle log - 320 Right log – 650 Main burner – 650	Left log – 120 Middle log - 60 Right log – 120 Main burner - 220
Nominal gas Consumption	46 MJ/h	46 MJ/h
Inlet Pressure	1.13kPA	2.75
Test Point Pressure	0.73 kPa	1.6 kPa
Direct Flueing	100/150mm	100/150mm

The following table explains the acronyms used.

FR	Front	TU	Tunnel
RS	Right Side	H/HH	High/Higher (For all models)
LS	Left Side	TR	Traditional
TS	Three Sides	SA	Console Appliance

Prior to Installation

Locate the Fireplace

Keep the following factors in mind when selecting a location for the fireplace:

- Fireplace clearance requirements (review “General Clearances” sections).
- Heat release and air intake requirements (review “Heat Release” and “Air Intake” sections).
- Adequate space for servicing.
- Access panel recommendations (review “Access Panel” section).
- Minimum vertical flue rise, allowed horizontal lengths, and elbow usage (review “Flueing” section).
- Framing and finishing requirements (review “Framing” and “Finishing” sections).
 - Front wall installation and finishes to be completed after fireplace and flue installation (review “Step-By-Step Cavity Construction” section).
- Floor or Platform requirements (review “Platform” section).

Fireplace Installation

Use the following guidelines to ensure a smooth installation. The installation sequence is divided into three phases: Planning, Installation, and Start-up.

First Trip to Site: Planning

Consult with the contractor and go over all requirements:

- Cavity framing requirements.
- 9 mm Cement Sheet (or equivalent) requirements.
- Heat release requirements.
- Air Intake requirements (if applicable).
- Access panel size and location.
- Gas and electric specs and location.
- Flue configuration.
- Finishing details.

NOTE: Provide the contractor with a printed copy of the “Building Checklist” and review requirements with them.

Second Trip to Site: Installation

- Confirm the following items are properly located and built to specification:
 - Framing (with 9 mm Cement Sheet)
 - Platform
 - Gas and electric
 - Access panel
 - Heat release
 - Air intake (if applicable)
- Clear a path free of any possible obstruction to carry in the fireplace.
- Unpack the fireplace and set in place.
- Secure the fireplace by attaching the seismic brackets to the framing. See “Securing the Fireplace” section below.
- Remove plastic sleeve covering pilot tube and electrical wires.
- Remove all zip ties.
- Optional: Remove gas and electrical components from metal shipping plate if desired.
- Move the components to the access panel location. Be mindful of the routing for future service needs.
- Verify the light grounding cable is connected to the firebox.
- Install the flue components. See “Flue Installation” section below.
- Review the front wall requirements (see “Step-By-Step Cavity Construction” section) and finishing details with the contractor.
- Protect the fireplace and components from damage.

WARNING: LIP INSTALLATION IN H FIREPLACES

To ensure the glass is removable after installation, Magnetic Screw (Part #M03) under the fireplace lip **must** be secured tightly to the firebox and screwed in as far as possible prior to installation of framing and finish material. If the magnet is not completely screwed down into the firebox, the lip will sit ajar to the firebox, preventing glass removal.

Securing the Fireplace

The fireplace has nailing flanges attached to the face of the fireplace (see figures below). The nailing flanges are to be attached into the framing upon installation. It is crucial to the finishing that the fireplace is stable, level, and plumb. For added stability (though not required), re-use the shipping brackets to secure the legs of the fireplace to floor/platform.

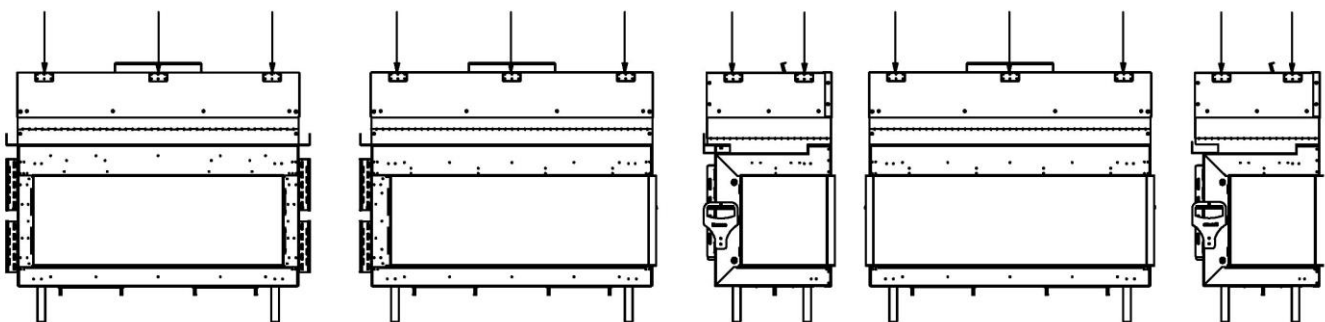

Nailing Flanges for Front Facing

Nailing Flanges for Corner (RS/LS)

Nailing Flanges for Three Side

Securing the Fireplace

During shipping, two L-shaped seismic brackets are attached from the fireplace to the crating for stabilization. These brackets must be re-used during installation to secure the fireplace to the back (or side) framing. It is crucial to the finishing that the fireplace is stable, level, and plumb. For added stability (though not required), re-use the leg shipping brackets to secure the legs of the fireplace to floor/platform.

Flue Installation

Flueing must be installed according to the requirements detailed in the “Flueing” section of this manual in conjunction with the flue system manufacturer’s installation instructions. Flueing must be supported by the support surrounding and not by the fireplace. Each offset (elbow) must be strapped to reduce movement or possible disconnection.

The first section of flueing must be secured to the fireplace starter collar with a minimum of 3 sheet metal screws no longer than 13 mm. DO NOT use silicone to seal the sections. If sealing is required by the flue manufacturer or local code, use Mil-Pac sealant.

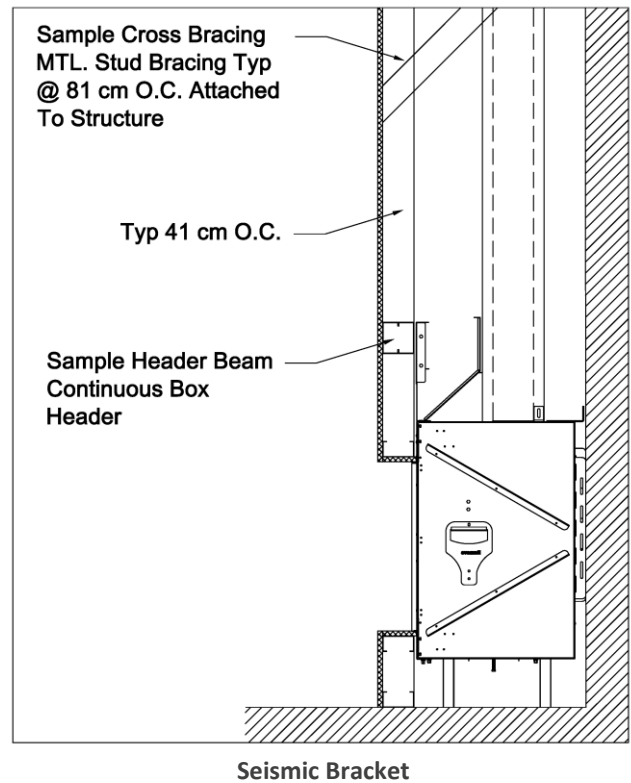

Third Trip to Site: Start-up

- Perform a visual inspection to confirm that all work was completed correctly and per specification.
- Confirm that gas and electric are properly connected and live and operating the specs specified within this manual.
- Remove the safety barrier and glass and clean the inside of the fireplace.
- Install the Interior Design Media (if desired) on the burner as specified in “Interior Design Media” section.
- Confirm the fireplace is operating properly.
- Check remote-control setup.
- Remove protective layer from glass.
- Clean glass.
- Reinstall the glass and safety barrier.
- Review operation of the fireplace and remote control with the owner.
- Set up return visit to clean glass after the Initial Burning Period (see “Post-Installation” section below).

Working with Glass Panels

Inner glass panel is 5mm ceramic glass. For fireplaces with a double glass heat barrier, exterior glass panel is 5 mm tempered glass.

Silicone comes pre-applied to any glass-to-glass connections (multi-sided models), on both sides of the glass. Keep the following guidelines in mind when handling silicone and glass panels:

The purpose of the silicone is to create a gasket, not to “glue” the glass panels together. When placing glass panels, ensure that the glass is fully in place and that the silicone is filling the space between the glass panels. Place the front (or centre) panel in place first and then slide the side panel into place so that the silicone edge touches the glass edge.

Post-Installation

Complete the following post-installation steps upon 4th trip to site.

Initial Burning Period

There is a 12-hour minimum burning period following installation of the fireplace. This 12-hour period must include a minimum of 4 consecutive hours of continuous burning. During this time, the owner or installer may notice:

- The glass developing a white or “cloudy” residue.
- An unusual smell

Both the residue and the smell are due to the paint on the fireplace metal heating and “burning off”. This is normal. The cloudiness and odour will disappear after the 12-hour period elapses and the installer returns to service the fireplace and complete start-up.

Final Inspection Procedure

When the 12-hour burning period is complete, the installer must return and perform the final inspection, which includes:

- Cleaning the glass with a ceramic glass cleaner (otherwise the white residue will remain)
- Checking the interior media setup
- Checking for gas leaks
- Checking for spillage
- Adjusting the restrictor (if necessary)
- Performing an overall check to make sure that all systems and components is working properly.

When these activities are complete, initial start-up is concluded and the fireplace may be operated by the owner.

Final Checks and User Instruction

Before releasing the fireplace to the customer for use without installer supervision, the installer must ensure that the fireplace is burning correctly. In addition, the installer must review and explain the following to the owner:

- Safety warnings
- Fireplace operation
- Warranty requirements
- Maintenance requirements
- Glass and firebox components are hot during and after operation.
- If any questions or concerns arise, owner must contact the local Ortal dealer/installer for support.

Building Checklist

The following building checklist is a quick reference for a typical Ortal Built-In Series fireplace installation. This list is not exhaustive and does not supplement thorough review of the installation manual.

- ☑ **Fireplace Location:** Ensure the location allows for min. 90 cm clearance from viewing area to combustibles and 30 cm to non-combustibles. Make sure a clear path is established to allow the fireplace to be safely transported to installation location.
- ☑ **Flueing:** Confirm flue size 100/150, flue clearance (25 mm on sides and bottom, 80 mm on top), flue configuration, and termination location.
- ☑ **Height from Floor:** Fireplace leg height is 25 cm (to bottom viewing area). Legs cannot be removed/altered. If desired viewing area location on the wall is higher than 250 mm, a platform can be built for the fireplace to stand on.
- ☑ **Cavity Floor/Platform:** Fireplace can stand on the Cavity floor or a platform. Floor or platform must be able to bear the weight of the fireplace. It can be constructed out of wood, concrete, metal, or any other solid materials (not required being non-combustible).
- ☑ **Cavity Construction:** No materials can be attached directly to the fireplace (exception: 9 mm Cement Sheet). The area of the cavity interior must meet minimum cavity area requirements (depending on the model). All cavities require a heat release, and double glass fireplaces require an air intake (details below).
- ☑ **Framing:** Adhere to minimum framing dimensions (or greater). Keep min. 50 mm clearance from back and sides (as applicable by model) of fireplace to any material. The first 46 cm above the top of the fireplace viewing area must always be non-combustible framing. Maintain min 7 mm clearance from front face of fireplace and front metal offset to the framing. Maintain min. 10 cm space between air flues at top of fireplace to any material. For recessed fireplaces, do not exceed 45 cm max. front overhang depth limit. Side overhang depth is unlimited. No material is permitted to extend past the metal lip surrounding the fireplace viewing area to allow for glass removal.
- ☑ **Drywall Requirements:** One layer of 9 mm Cement Sheet (or equivalent) must be installed on the exterior of the Cavity framing.
- ☑ **TV/Artwork:** TV/Art must be min. 100 mm above top of fireplace viewing area.
- ☑ **Gas Supply Line and Power Location:** Locate gas line with manual shut off according to local code. Power provided by single gang 240V outlet in same area as gas line.
- ☑ **Access Panel:** Access panel highly recommended to access gas and electrical components for servicing. Depending on the model, access panel can be placed at side or back of the fireplace within 1 metre of the pilot. Access panel or some other form of clear access to the Cavity is required for power-flued fireplaces. Size recommendation: as large as possible depending on application. Min. recommended size 25 cm x 25 cm.
- ☑ **Heat Release:** *Crucial for Cool Wall Technology.* Must start within 15 cm (max.) from the Cavity's ceiling. Heat release must meet minimum size (depending on the model) of net free air space. Height of the heat release must not exceed $\frac{1}{3}$ of the width.
- ☑ **Air Intake:** Only required for double glass heat barrier. Must be located below glass level, according to drawing. Air intake must meet minimum size (depending on the model) of net free air space.
- ☑ **Finishing:** For finishes flush to the fireplace, no clearances are required. For finishes where the fireplace is recessed to the finish, maintain 3 mm from the finish to the front face of the fireplace.

Framing

Fireplace cavity may be framed with either combustible (typically wood studs) or non-combustible framing (typically metal studs). **Any framing within 45 cm from the top of the fireplace glass (viewing area) must be non-combustible.** This does not apply to the framing to the back or side(s) of the fireplace; these may be combustible.

The fireplace is non-load bearing. The framing of the fireplace Cavity must be designed to carry the entire weight of the wall and finish material. Surrounding material must not transfer weight to the fireplace (exception: 9 mm Cement Sheet or equivalent), or be connected in any way to the fireplace.

No material is permitted to extend past the metal lip surrounding the fireplace viewing area. This area must be unobstructed to allow the heat barrier and inside glass panel to be removable.

 **IMPORTANT: To ensure the glass is removable after installation, Magnetic Screw (Part #M03) under the fireplace lip must be secured tightly to the firebox and screwed in as far as possible prior to installation of framing and finish material. If the magnet is not completely screwed down into the firebox, the lip will sit ajar to the firebox, preventing glass removal.**

Framing Dimensions

The following diagrams are for illustrative purposes only. There are multiple approved installation scenarios. A flush application is not the only permitted application. The fireplace may be recessed into the wall. Refer to diagrams and values below and in the following pages for details.

Front Facing Series Framing

Combustible Framing

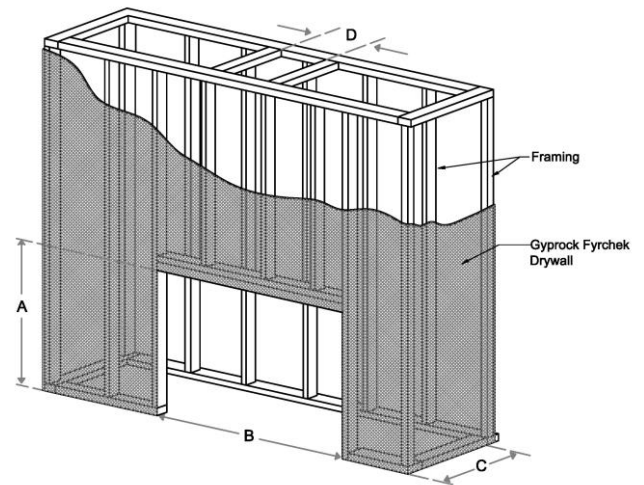
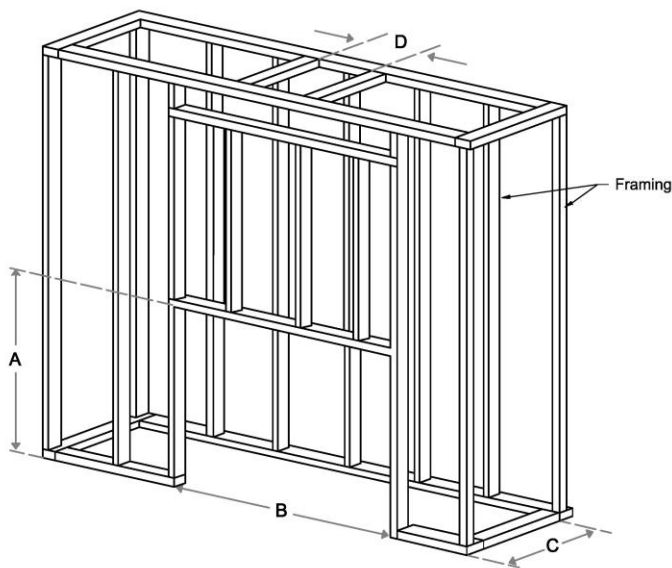

Dimension A: Rough Framing Opening Height
 Dimension B: Rough Framing Opening Width
 Dimension C: Framing Depth
 Dimension D: Firestop Opening

⚠ WARNING – MAINTAIN AIR FLOW CLEARANCE: Firebox top flue must have minimum 10 cm of clearance to any material achieve sufficient airflow. Failure to do so could result in improper fireplace operation, property damage, or physical injury. Review “General Clearances” section prior to framing to ensure all clearances are followed.

Model	Framing	Dimension A	Dimension B	Dimension C	Dimension D
90H F	Combustible	125 cm	117 cm	55 cm	Refer to pipe manufacturer's firestop dimensions
110 F	Combustible	110 cm	134 cm	55 cm	
110H F	Combustible	125 cm	134 cm	55 cm	
130 F	Combustible	110 cm	151 cm	55 cm	
130H F	Combustible	125 cm	151 cm	55 cm	
150 F	Combustible	110 cm	176 cm	55 cm	
150H F	Combustible	125 cm	176 cm	55 cm	
170 F	Combustible	110 cm	196 cm	55 cm	
170H F	Combustible	125 cm	196 cm	55 cm	
200 F	Combustible	110 cm	220 cm	55 cm	
200H F	Combustible	125 cm	220 cm	55 cm	

Corner (RS/LS) Series Framing

Combustible Framing

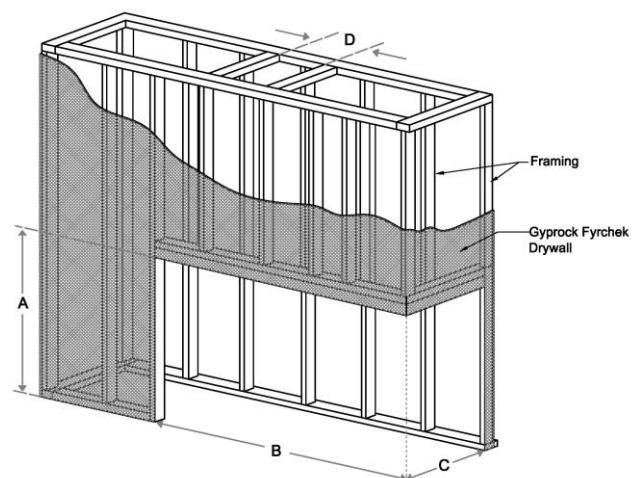
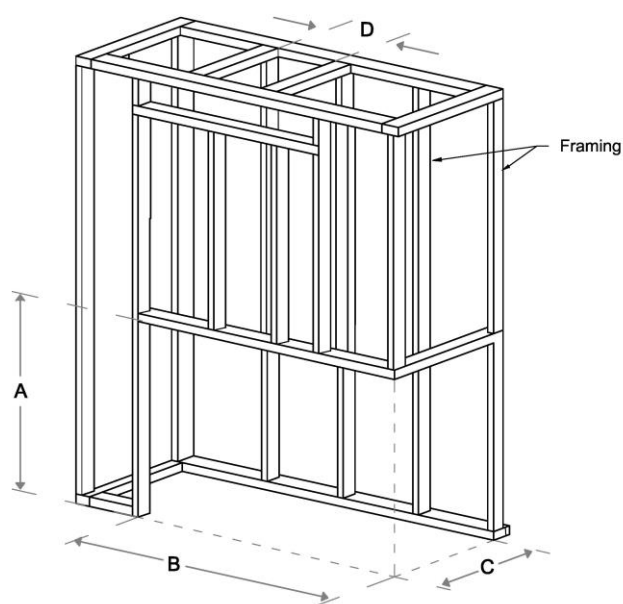

Dimension A: Rough Framing Opening Height
 Dimension B: Rough Framing Opening Width
 Dimension C: Framing Depth
 Dimension D: Firestop Opening

⚠ WARNING – MAINTAIN AIR FLOW CLEARANCE: Firebox top flue must have minimum 10 cm of clearance to any material achieve sufficient airflow. Failure to do so could result in improper fireplace operation, property damage, or physical injury. Review “General Clearances” section prior to framing to ensure all clearances are followed.

Model	Framing	Dimension A	Dimension B	Dimension C	Dimension D
90H RS/LS	Combustible	125 cm	112 cm	55 cm	Refer to pipe manufacturer's firestop dimensions
110 RS/LS	Combustible	110 cm	129 cm	55 cm	
110H RS/LS	Combustible	125 cm	129 cm	55 cm	
130 RS/LS	Combustible	110 cm	146 cm	55 cm	
130H RS/LS	Combustible	125 cm	146 cm	55 cm	
150 RS/LS	Combustible	110 cm	171 cm	55 cm	
150H RS/LS	Combustible	125 cm	171 cm	55 cm	
170 RS/LS	Combustible	110 cm	191 cm	55 cm	
170H RS/LS	Combustible	125 cm	191 cm	55 cm	
200 RS/LS	Combustible	110 cm	215 cm	55 cm	
200H RS/LS	Combustible	125 cm	215 cm	55 cm	

Three Side Series Framing

Combustible Framing

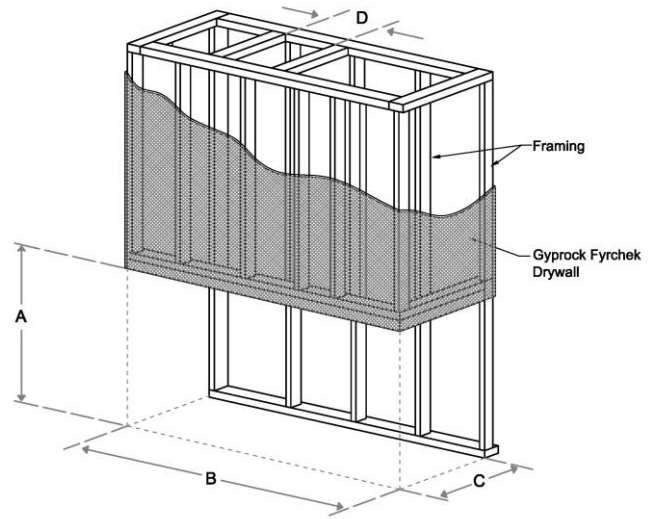
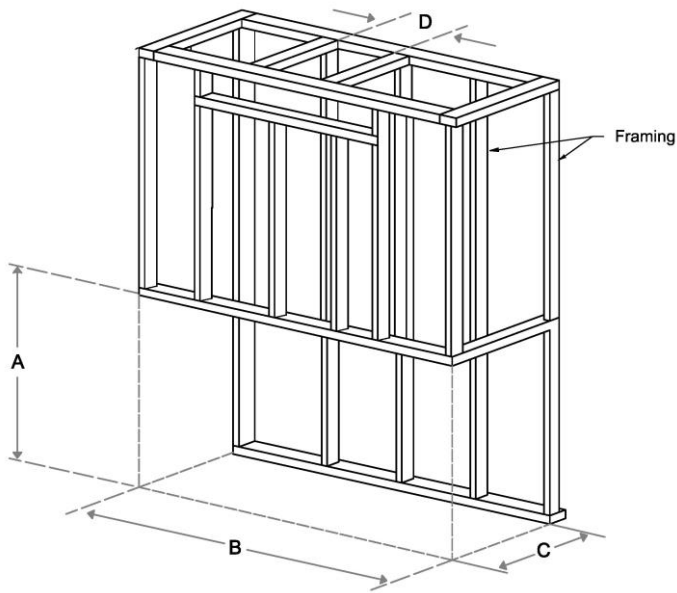

Dimension A: Rough Framing Opening Height
 Dimension B: Rough Framing Opening Width
 Dimension C: Framing Depth
 Dimension D: Firestop Opening

⚠ WARNING – MAINTAIN AIR FLOW CLEARANCE: Firebox top flue must have minimum 10 cm of clearance to any material achieve sufficient airflow. Failure to do so could result in improper fireplace operation, property damage, or physical injury. Review “General Clearances” section prior to framing to ensure all clearances are followed.

Model	Framing	Dimension A	Dimension B	Dimension C	Dimension D
90H TS	Combustible	125 cm	106 cm	55 cm	Refer to pipe manufacturer's firestop dimensions
110 TS	Combustible	110 cm	124 cm	55 cm	
110H TS	Combustible	125 cm	124 cm	55 cm	
130 TS	Combustible	110 cm	141 cm	55 cm	
130H TS	Combustible	125 cm	141 cm	55 cm	
150 TS	Combustible	110 cm	166 cm	55 cm	
150H TS	Combustible	125 cm	166 cm	55 cm	
170 TS	Combustible	110 cm	186 cm	55 cm	
170H TS	Combustible	125 cm	186 cm	55 cm	
200 TS	Combustible	110 cm	210 cm	55 cm	
200H TS	Combustible	125 cm	210 cm	55 cm	

Cavity Floor/Platform

The fireplace must be installed on a flat, solid, continuous surface. Surface can be wood, concrete, metal, and other typical solid floor types. Surface material is not required to be non-combustible.

Fireplace leg height is 25 cm (measured to bottom of viewing area). Legs cannot be removed, cut, or adjusted.

Raised Platform Option: To raise the fireplace higher than 25 cm height, build a platform for the fireplace to stand on. Platform must be stable and able to bear the full weight of the fireplace. Platform can be constructed out of wood, concrete, metal, or any other solid materials. Platform material is not required to be non-combustible.

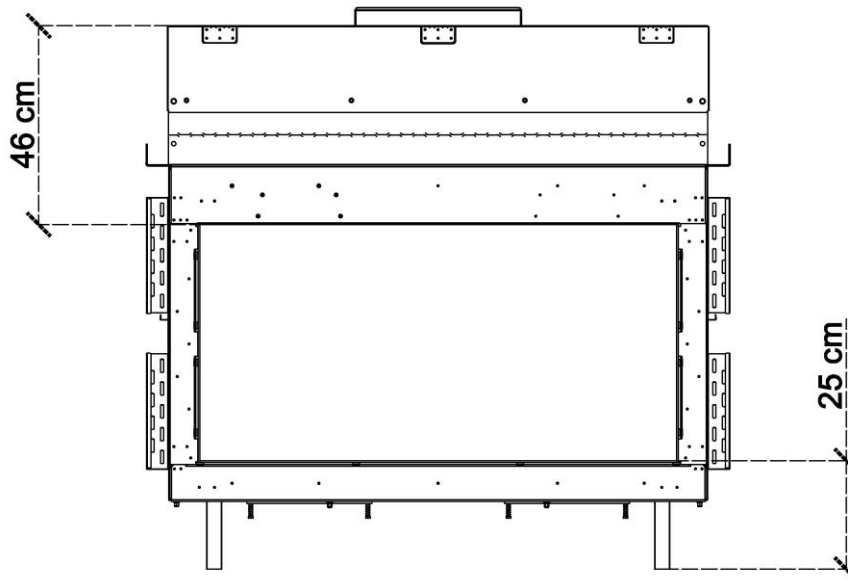

NOTE: An air intake is necessary to incorporate into the platform depending on the design. See “Air Intake for a Platform” for details.

Hearth Extension

A hearth extension is not required. Any hearth extension used is for appearance only and does not have to conform to a standard hearth extension installation requirement.

General Clearances

Viewing Area Clearances

The viewing area clearance zone is an area that extends perpendicular from the fireplace viewing area. The depth of the viewing area clearance zone depends on the combustibility of the material in question. Distance is measured from the fireplace heat barrier.

Non-Combustible Materials	Must be minimum 300 mm from fireplace viewing area.
Combustible Materials	Must be minimum 920 mm from fireplace viewing area.

Materials (including combustible flooring and combustible finish material) are permitted below and around the viewing area clearance zone.

IMPORTANT NOTE: When placing material near the glass, take care to consider fireplace serviceability. It is strongly recommended that any items/materials placed in front of the front (long) glass be movable for easy access to the fireplace during servicing. Recommendation does not apply to side (short) glass(es).

Maintain a **50 mm** clearance from the back and/or side of the fireplace (depending on the model) to any material.

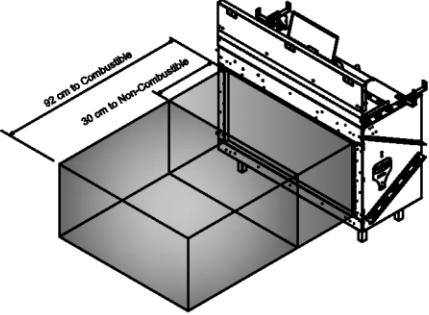
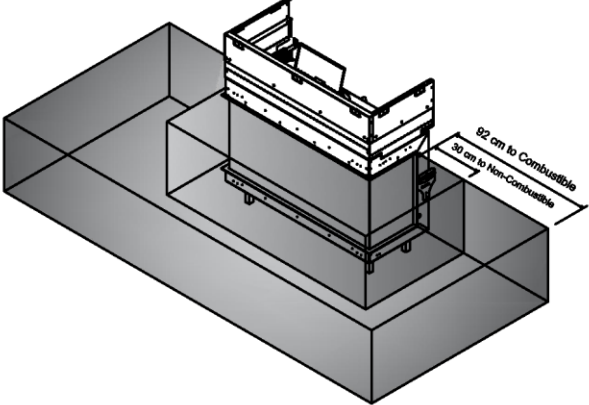
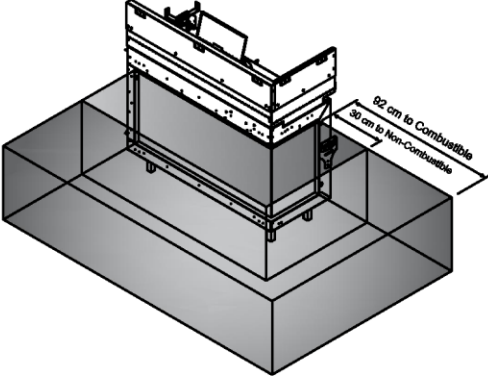
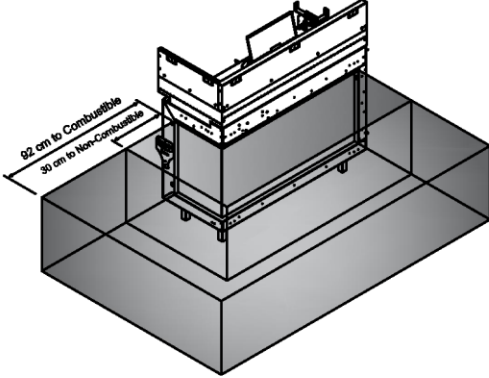
Viewing area clearances per model	
Front	Three side
	
Corner: Right side	Corner: Left side
	

Firebox Clearance

Firebox Clearance Per Model

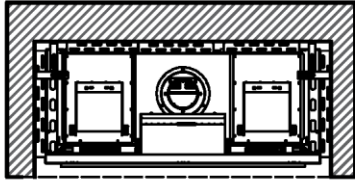

Front & Traditional

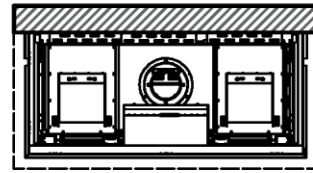

Three Side

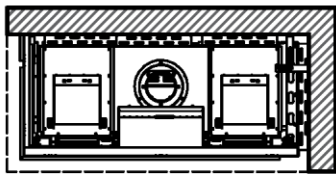

Corner: Left Side

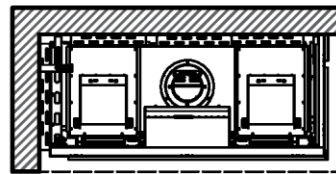

Corner: Right Side

Clearance to Cavity Ceiling

Maintain a **46 cm** clearance from the top of the fireplace viewing area to the lowest point of the ceiling or to any building materials.

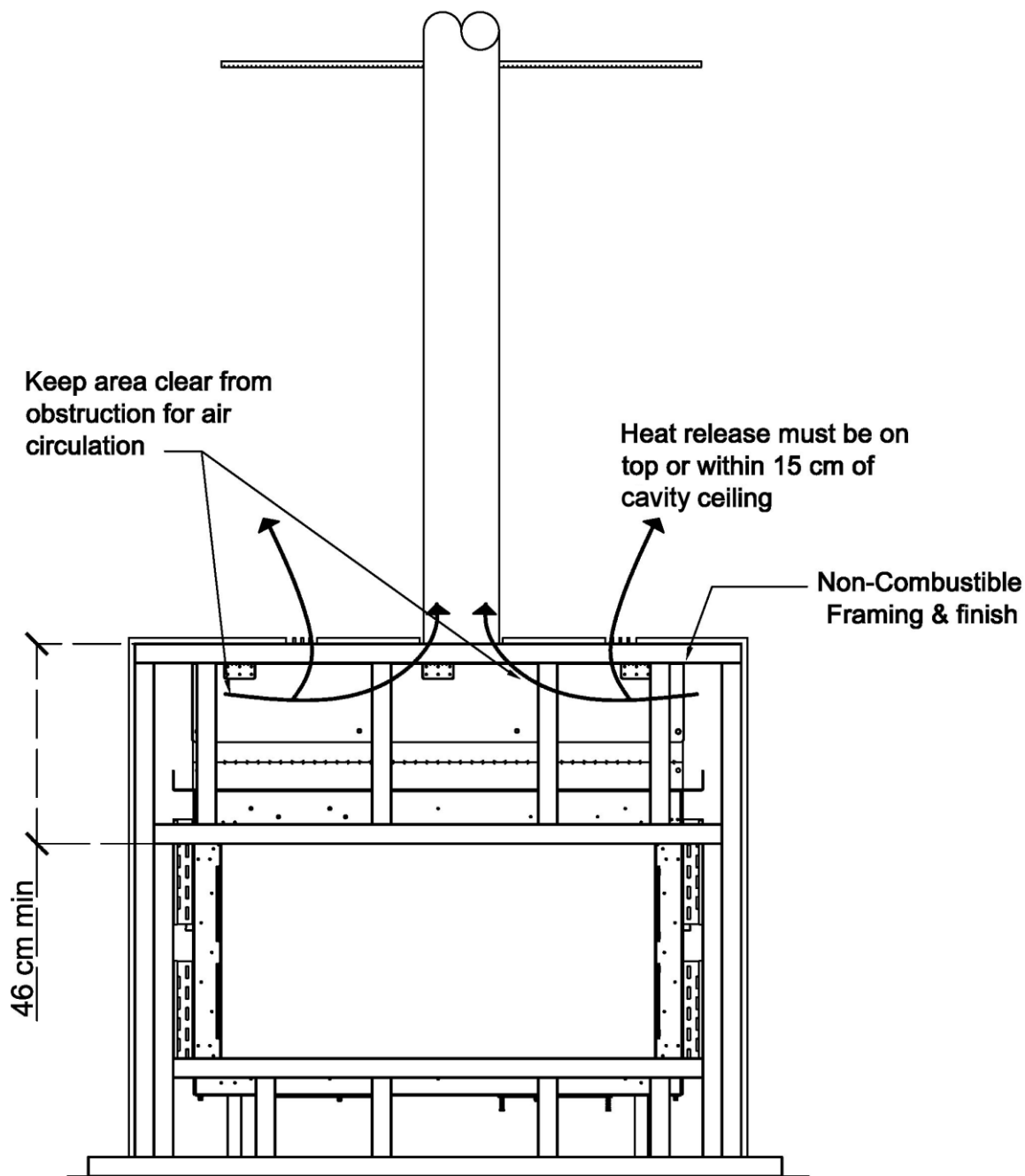

Minimum Cavity Ceiling Clearance Diagram

NOTES:

- A heat release is required for every installation, but it is not required to be split between the two sides of the Cavity as shown in the diagram above. It is shown in this diagram for illustrative purposes only. See the "Heat Release Requirements" section for details.

Clearance around the flue pipe must be maintained

(25 mm clearance on the sides and bottom, 75 mm on top). See the "Error! Reference source not found."

Air Flow Clearance

A **100 mm** clearance from the heat barrier flue openings along the top of the fireplace is required. Framing and building material is **NOT** permitted in this area. Doing so will block the flues and cause the entire surrounding to overheat.

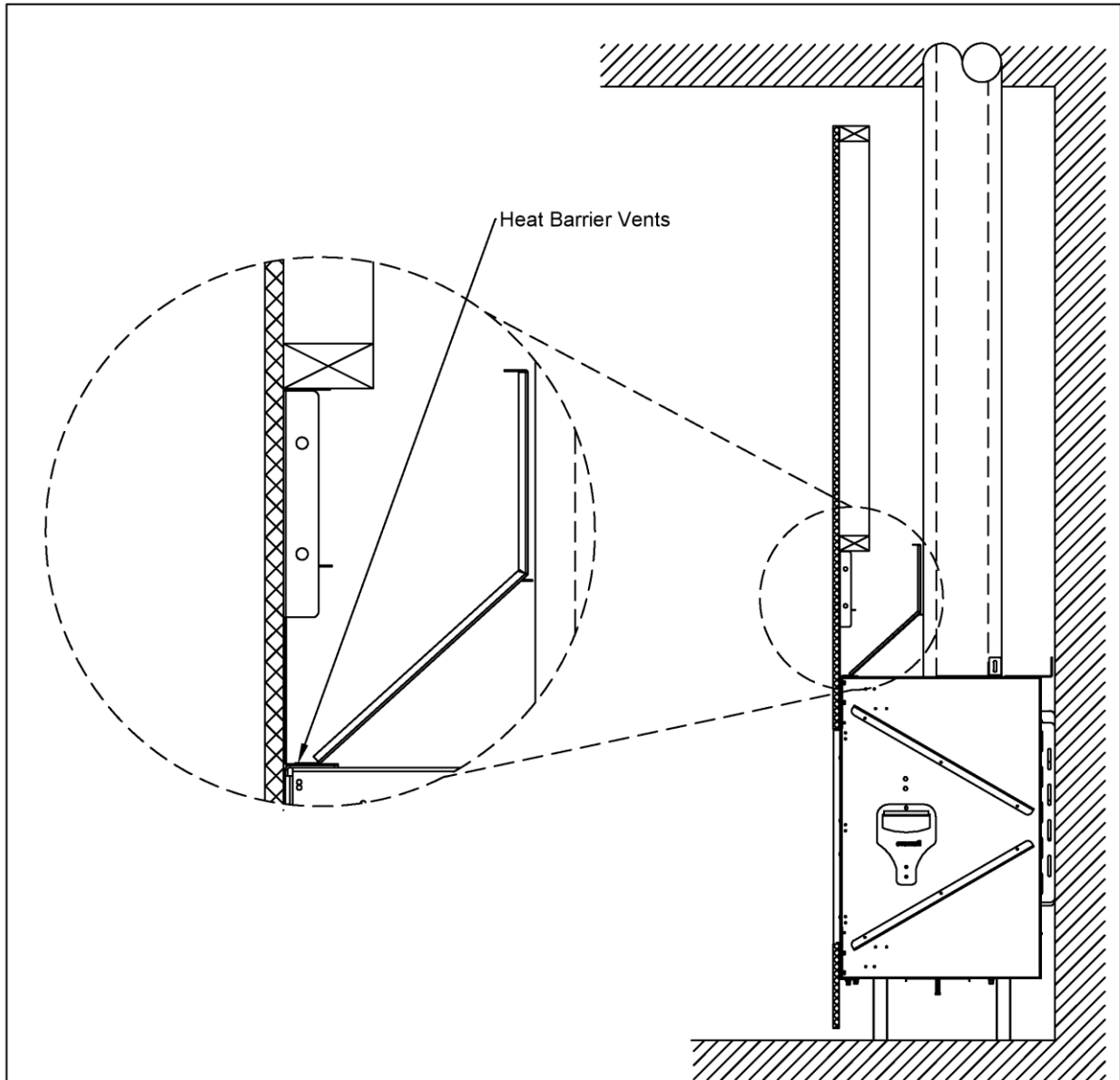

! NOTE: It is acceptable if the flat stud immediately above the fireplace hangs over heat barrier flues *slightly* when using standard metal framing (as shown in diagram above).

Zero-Clearance Stand-Offs

The fireplace has zero-clearance stand-offs fastened to the body of the fireplace as shown in the figures below. Stand-offs must be fully extended upon installation.

Heat Shield: Attached to the top front part of the fireplace. It is foldable at the attachment site on top of the fireplace and $\frac{2}{3}$ to the top of the shield. The heat shield serves to direct the heat coming out the of the heat barrier vents at the top of the fireplace and maintains clearance to the vent pipe.

Side & Back Framing Stand-offs: Attached to the sides and back of the fireplace. These stand-offs keep enough distance from the fireplace to the framing to allow for proper airflow inside the chase. These stand-offs can directly touch combustible framing.

Front Framing Stand-offs: Attached to the front top portion of the fireplace above the glass viewing area. It keeps a clearance above the heat barrier vents on the top of the fireplace to ensure proper air flow inside the chase. The top of this stand-off can directly touch combustible framing. Any framing in front of the stand-off must be non-combustible.

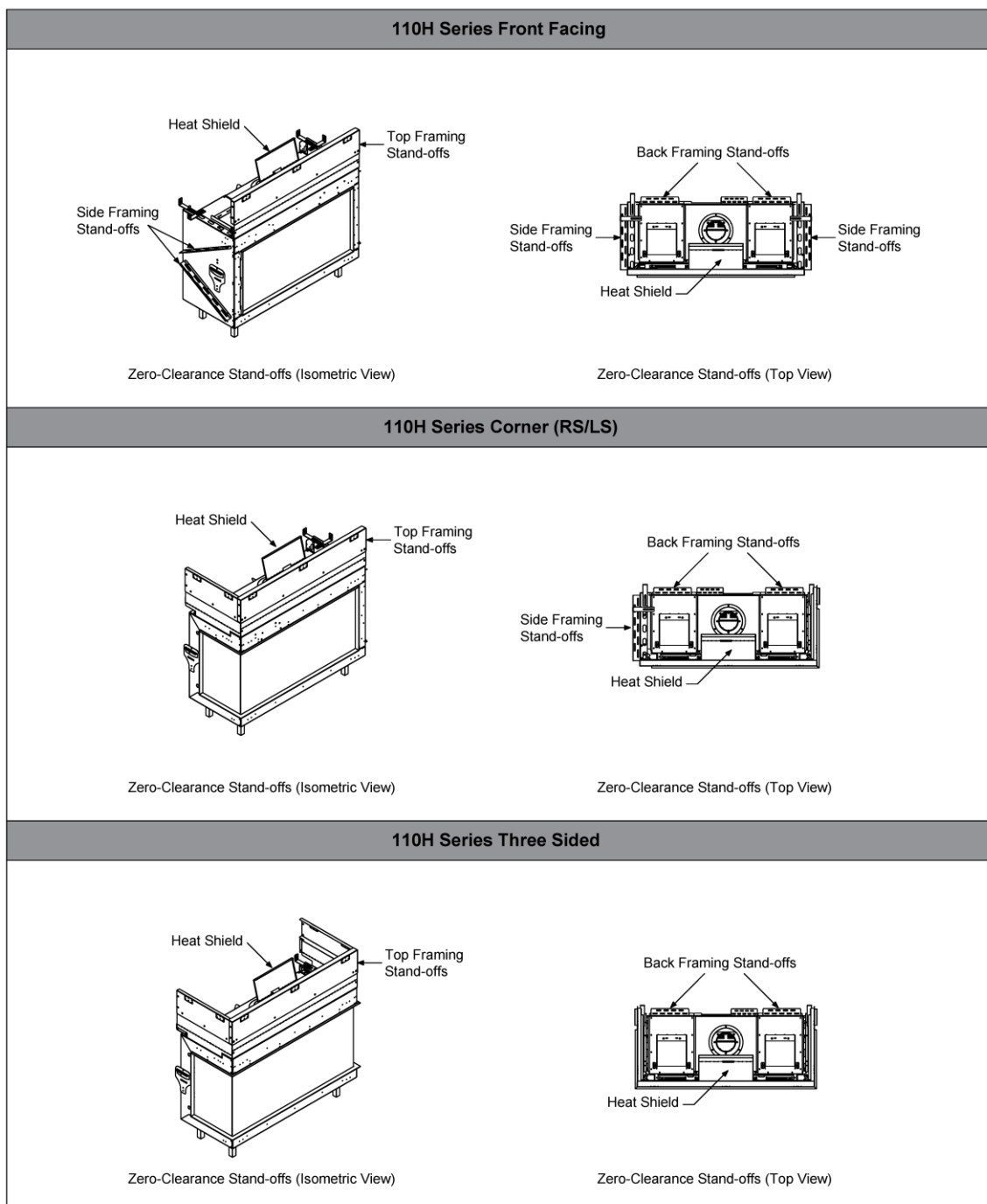

Framing Clearance

Clearance to a Side Wall

The fireplace viewing area is zero-clearance to a sidewall. A sidewall is defined as a wall that meets the viewing area at a 90° angle.

 = Building Material

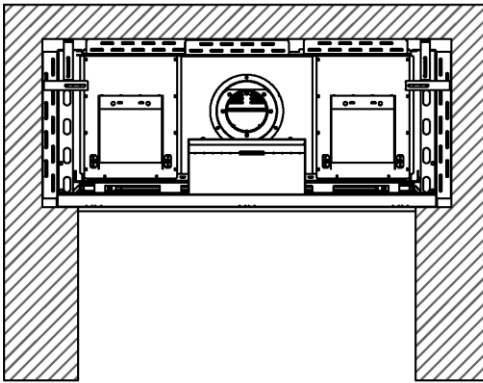

Alcove Side Walls (top view)

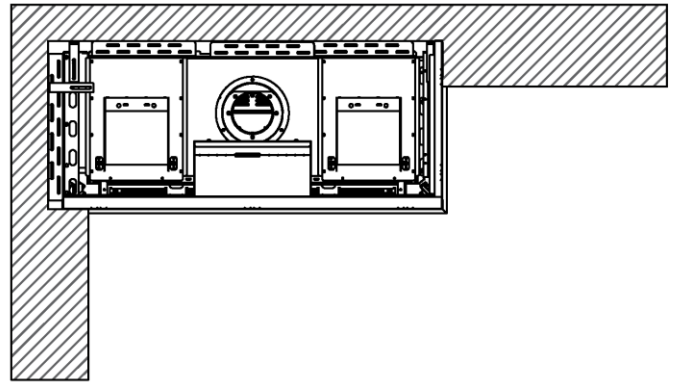

Corner Side Walls (top view)

The temperature on the sidewall can get as high as 65°C above ambient temperature. While the fireplace certification allows for this temperature variance, building and finish materials will have their own limitations. Consult the material manufacturer to ensure the material can safely withstand this temperature range.

This information does not apply to a wall that is constructed in front of the viewing area. For materials that will be in front of a main or side viewing area, please refer to the “Viewing Area Clearances” section.

Maximum Overhang Depth

Overhang depth of a recessed fireplace must not exceed the clearances shown in the diagrams below. Overhang depth is measured from the edge of the fireplace lip to the out-most part of the wall (including finish material).

Bottom recess (or “hearth extension”) has no minimum or maximum depth requirement. If bottom recess depth exceeds 30 cm, ensure the structure is capable of supporting the weight of a fireplace technician for servicing.

Front (Long Side) Overhang

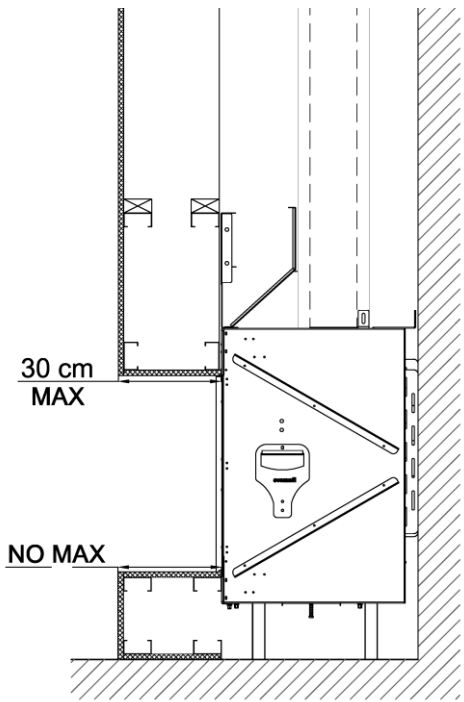

Side (Short Side) Overhang

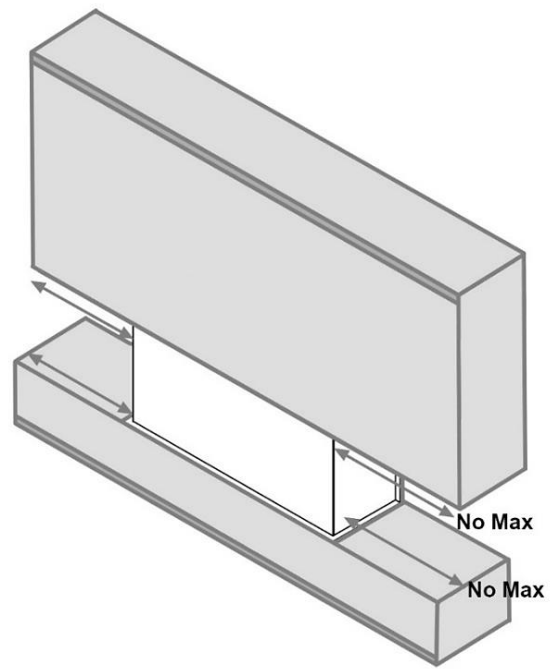

Heat Release

A heat release is an opening in the fireplace Cavity that allows the heat inside the Cavity to passively circulate into an interior room. This heat is generated convectively as the fireplace heats up. It is separate from exhaust heat produced at the combustion chamber of the fireplace. For safety purposes, a **heat release is required** to keep the wall around the fireplace cool.

Heat Release Requirements

- The heat release must be located at or near the top of the fireplace Cavity and **start within** 15 cm (0-15 cm max) of the Cavity ceiling/firestop. It can start at the Cavity ceiling. It can be located on the front, sides or back of the Cavity. It can be released into any interior space that shares a wall with the Cavity.
- Minimum heat release size requirement depends on heat release orientation:

Fireplace Series	Horizontal Heat Release	Vertical Heat Release
Wilderness	Minimum 800 cm ² . of free air space	Minimum 1000 cm ² . of free air space

* Heat release requirements do not apply to Stand-alone (Console Appliance) fireplaces.

- For horizontal heat releases only, the height of the heat release must not exceed 1/3 of the width. (This does not apply to vertical heat releases.)
- The space the heat release flues into must have a minimum volume of 5.2 cm³.
- The heat release can be in the form of (but not limited to) a louvered ventilation grille, gap, or reveal.
 - For louvered/perforated ventilation grilles, the net free air space allowed in the louvered area must be equal or greater than the minimum number of square centimetres required per fireplace.
- The interior area of the narrowest part of the fireplace Cavity (in square centimetres) must never be less than your required heat release size (see "Cavity Area Minimum" section for details).
- The heat release cannot be flued outdoors or to an unconditioned space.

 **NOTE: An angled heat release is not permitted.**

The following diagrams are examples of potential heat release options. These drawings serve as illustrative purposes only.

Horizontal Heat Release

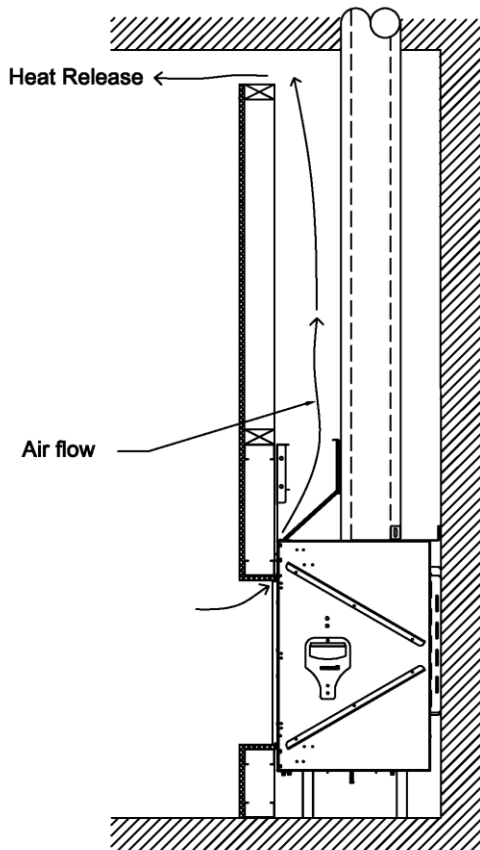

Reveal Heat Release

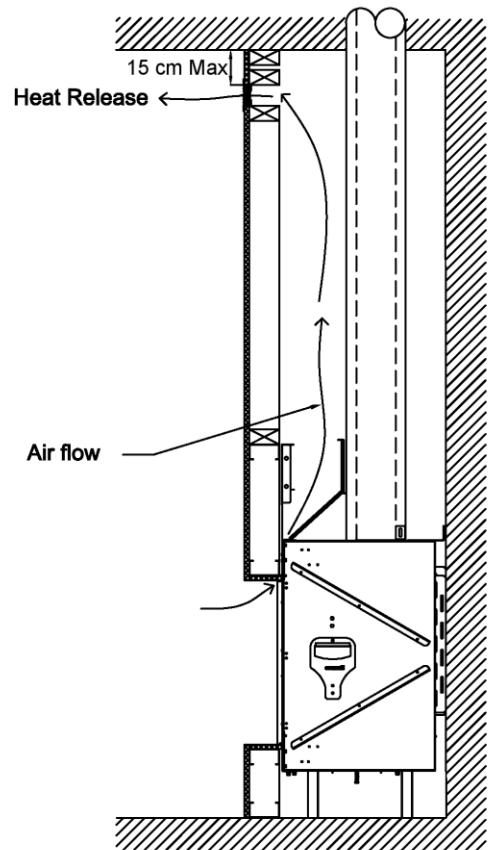

Louvered Grille Heat Release

Vertical Heat Release: Split Front

The heat release is oriented vertically and split between the two sides of the Cavity.

Vertical Heat Release: Full Side

The heat release is oriented vertically. Entire heat release is on one side of the fireplace Cavity.

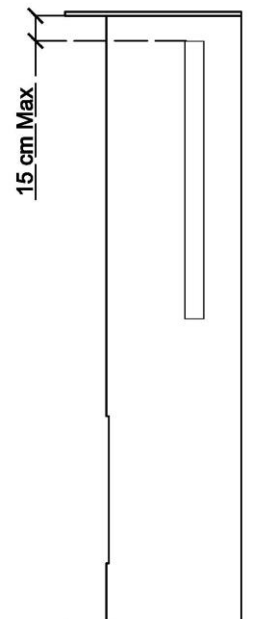
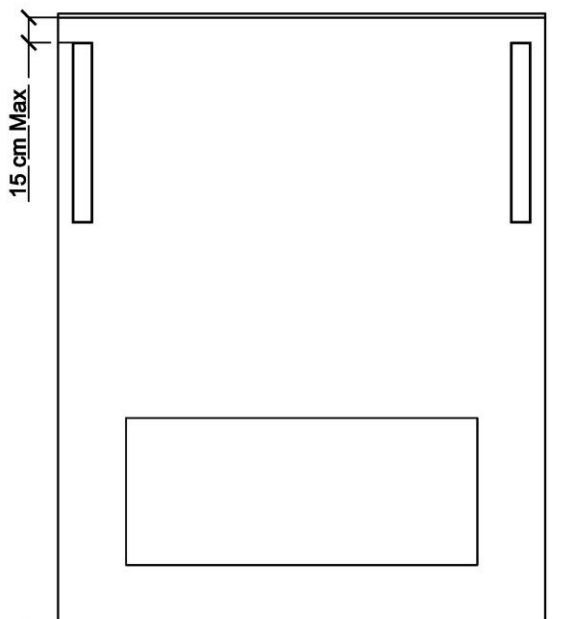

Sprinkler Clearance to Heat Release

In a situation where a sprinkler head is near the heat release, the sprinkler head must be minimum **600 mm** (linear length) from any point of the heat release opening.

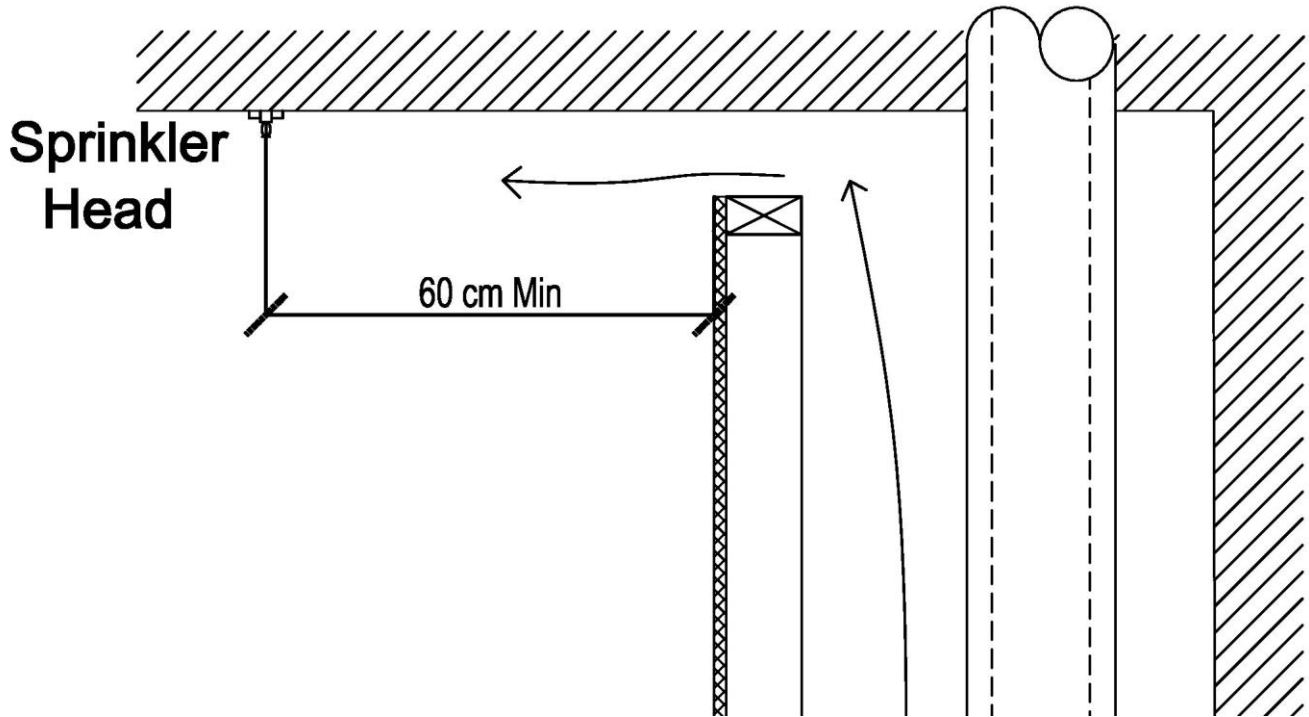

Air Intake

When installing a fireplace with a double glass heat barrier, it is essential to maintain cool airflow between the double glass panels. For this purpose, an opening must be provided toward the bottom of the wall to allow the double glass fans to circulate room air through the glass panels and up into the Cavity. This opening, called an air intake, needs to be made before closing the wall surface below the fireplace. Air intake must meet the minimum size requirement.

Fireplace Series	Air Intake
Wilderness	Minimum 800 cm ² . of free air space

The air intake can be in the form of a louvered/perforated ventilation grille, gap, or toe-kick (reveal). For louvered ventilation grilles, the net free air space allowed in the louvered area must be equal or greater than the minimum number of square centimetres required per fireplace.

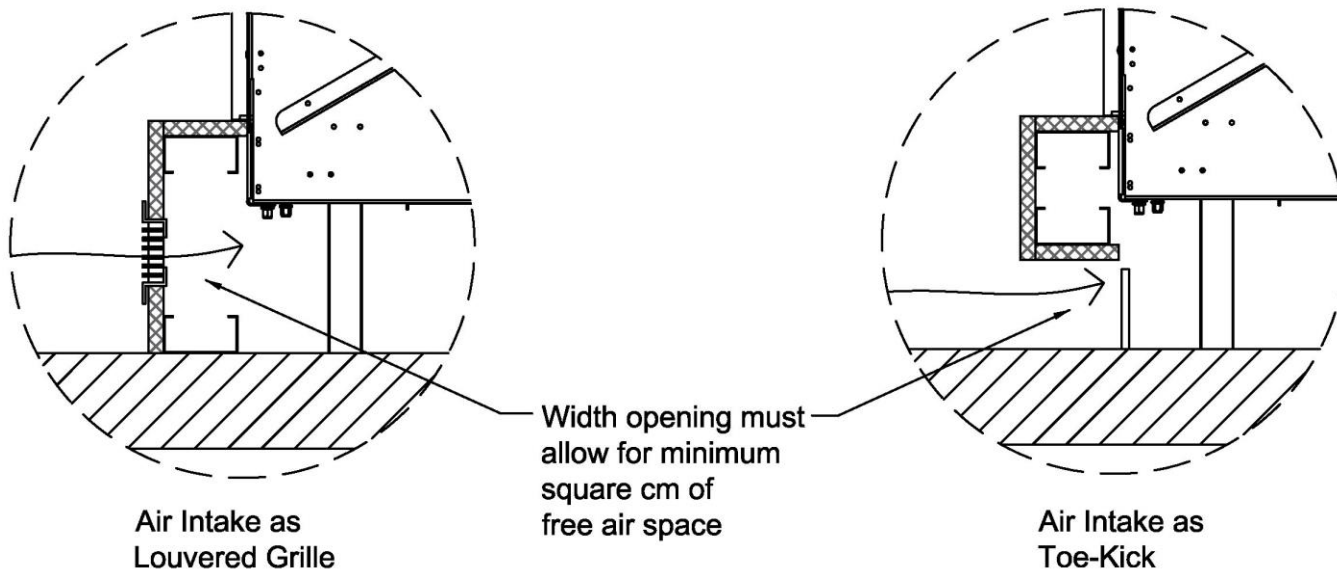

The entire air intake must be located at or below the level of the double glass fans. The air intake is not required to be on the front wall of the fireplace. The air intake cannot be on a wall that allows air from outside the house directly into the fireplace Cavity. Air must be from a conditioned space.

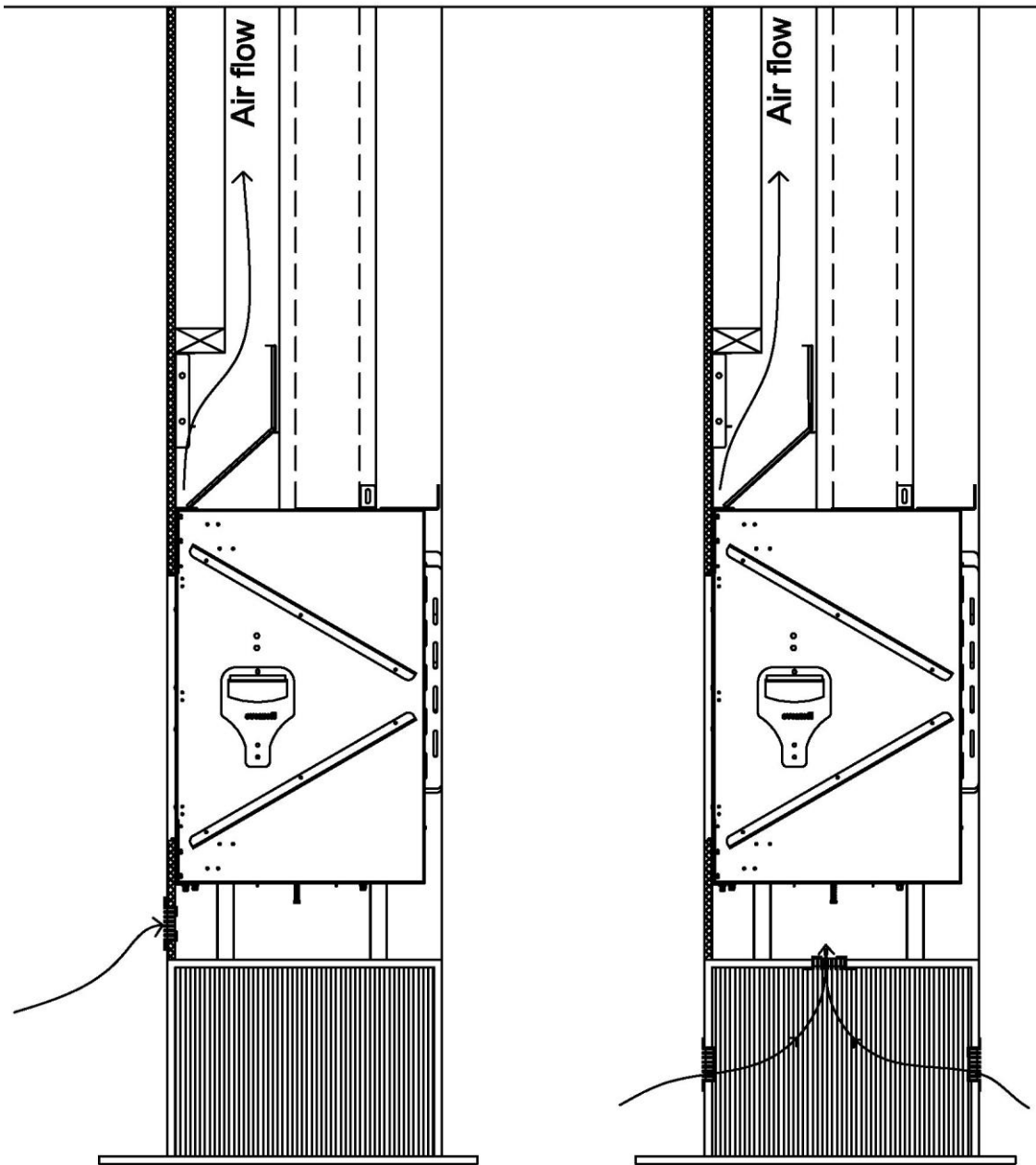

Air Intake for a Platform



LEGEND

-  Gyprock Fyrcheik Drywall
-  Combustible Framing

 **NOTE:** Please refer to the “Platform” section for details on platform construction.

Mounting a TV/Artwork

Ortal's Cool Wall Technology is a technique that reduces the convective heat from the fireplace and prevents heat build-up inside the fireplace Cavity, mitigating any damage that may result from the wall reaching high temperatures. Ortal's Cool Wall system enables the option of safely installing artwork, a TV, or other similar electronic components above the fireplace by reducing the wall temperature above the fireplace.

Location	Wall Temperature
0-15 cm above fireplace	38°C - 49°C
15-30 cm above fireplace	32°C - 38°C
30 cm above fireplace	27°C - 32°C

Maintain the following general requirements to mount a TV or artwork above the fireplace and prevent heat damage:

- Mount the TV or artwork at the minimum clearance above the top of the fireplace viewing area. Minimum clearance amount depends on flush or recessed installation. See sections below for more information.
- Wires inside the Cavity are not permitted to cross over the fireplace. Wires must be installed against a wall.

The decision to install a television above the fireplace is up to the discretion of the owner. TV and art manufacturers may specify that their product should not be installed on, near or above a heat source. Ortal will not be held liable for any adverse effects on a TV, artwork or other equipment located near the fireplace. It is the owner's responsibility to verify that their TV or artwork can withstand the wall temperatures as outlined in the above wall temperature chart.

The following diagrams can be used as a guide for customers who do decide to locate their TV and artwork above their fireplace. These drawings illustrate ways of reducing the amount of heat impact to the area surrounding the fireplace.

Flush Mounted TV/Artwork

When the TV is mounted on a wall that is flush to the fireplace, the TV must be at least **10 cm** from the top of the fireplace glass viewing area. Ensure all clearances are maintained. See diagram below for details.

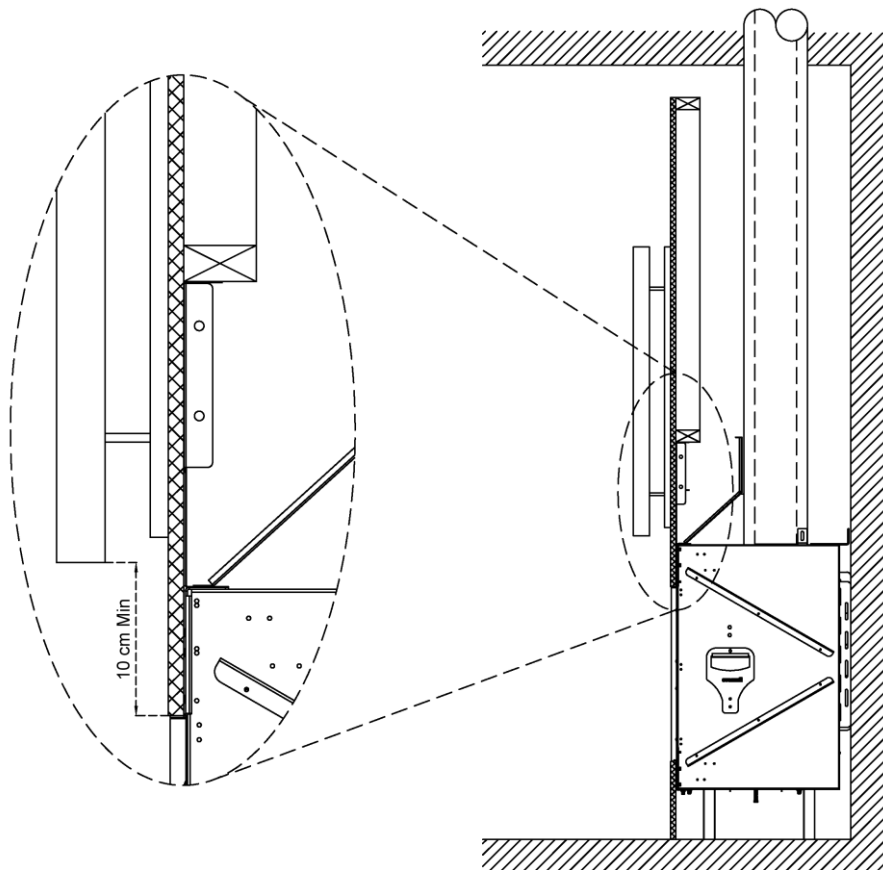

! NOTE: Flue clearances must be maintained. See “General Clearances” section for details.

Recessed TV/Artwork

When the TV is mounted on a wall that recesses over fireplace, the TV must be at least **10 cm** from the top of the fireplace glass viewing area.

At 10 cm above the fireplace viewing area, maximum possible recess is 10 cm. A deeper recess will interfere with required clearances to flueing. Maximum possible recess increases at <30 cm above the viewing area when flueing is offset (as shown in diagram below).

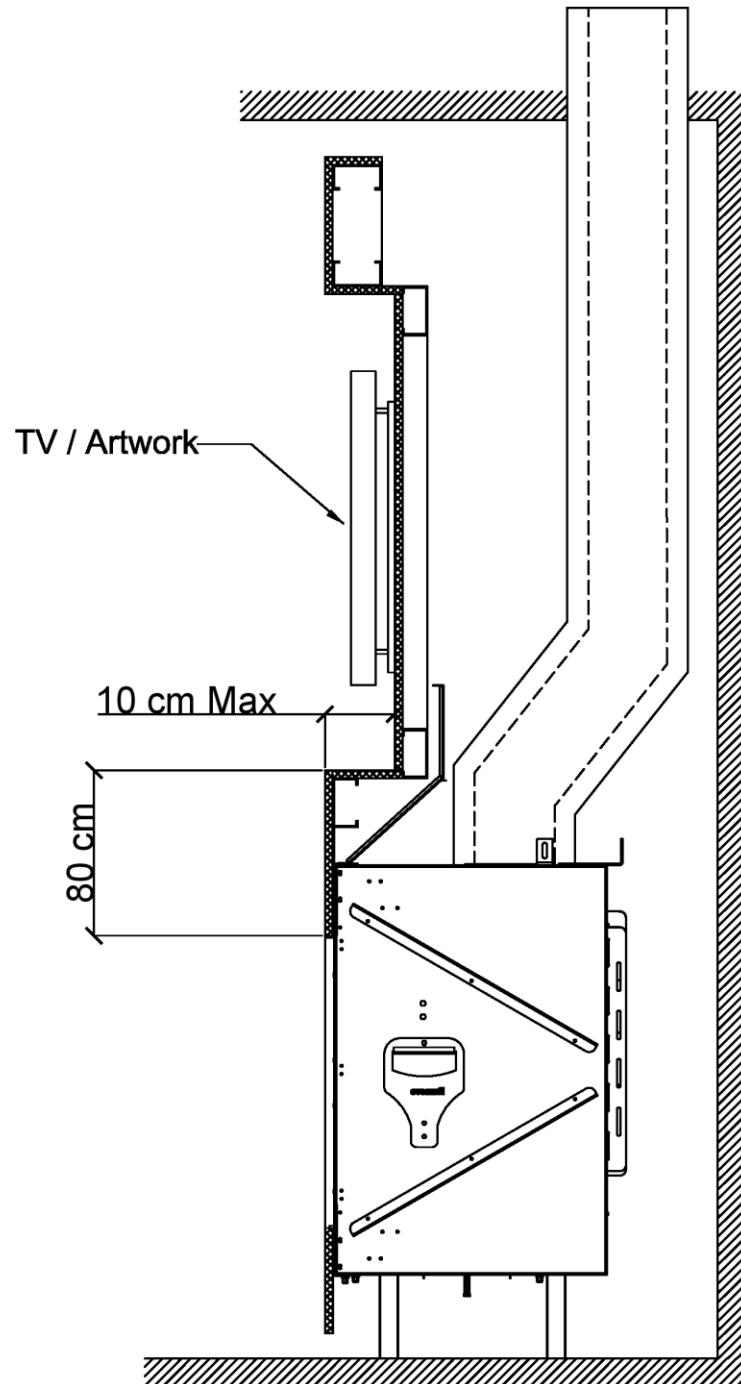

 **NOTE:** Flue clearances must be maintained. See “General Clearances” section for details.

Access Panel

An access panel is not required (see notes below for exception), but it is ***highly recommended***. It allows for access to the fireplace's gas and electrical components for servicing.

NOTE: An access panel, or some other form of clear access, is required for power flued fireplaces. For servicing purposes, the power flue control box (located at the fireplace) must be easily accessible in a way that does not require removal of the fireplace glass.

Access Panel Size and Location Recommendations:

- Minimum of 25 cm x 25 cm in size
- Located within 90 cm of the pilot to the side or back of the fireplace (see "Routing the Gas Line")

The size and location of the access panel may vary, but in all cases, it must allow the technician to comfortably access and service the fireplace's gas and electrical components. These components are attached to the pilot on a flexible gas line and can be moved within 90 cm of the pilot (located at the centre front of the burner).

For ease of access, move the fireplace's gas and electrical components as close to the access panel as possible. **If there is any distance between the access panel and the gas and electrical components, the access panel size must be increased accordingly.** Prior to installation, fireplace dealers/installers should work with the owner, builder, project architects and/or interior designers to determine the best size and location of their access panel.

If an access panel cannot be incorporated, the alternative method of servicing the gas and electrical components is through the fireplace. This procedure requires removing the glass panel(s) and interior design media, and lifting the grill, burner, and bottom pressure release valve. This will increase service time and difficulty. An access panel is always preferred. Fireplace dealers/installers are advised to consult with their clients regarding the advantages and disadvantages of each service option.

NOTE: If local code requires an access panel, defer to local code requirements.

Cavity Area Minimum

To ensure the convective heat within the Cavity passively moves to the heat release at an optimal rate, all parts of the interior of the Cavity must at least the same size as the fireplace heat release (see "Heat Release" section to determine your model's required heat release size) at size at any given point. To determine if your Cavity meets this requirement, use the following equation at the narrowest part of the Cavity.

Cavity Area = (Cavity Length x Cavity Depth) – (Area of the Pipe)

Area of the Pipe:

100/150 flueing = 182 cm²

Used for Power Flueing only

If the heat release is split into 25/75 portions due to an oversized ledge, the Cavity only needs to be the size of 75% of the heat release because 25% of the heat is already being released at the ledge (see "Ledge Detail" section below for details).

Recessed Partial Ledge

A ledge over the top of a fireplace that is less than 60 cm from the top of the fireplace viewing area must maintain a minimum of **30 cm from the top of the viewing area to the bottom of the building material. Entire structure must be non-combustible (framing and finish).**

If ledge surface area exceeds the values shown in the chart below, the heat release must be divided between the ledge and the Cavity ceiling: 25% at the ledge and 75% at the Cavity ceiling. This is referred to as an oversized partial ledge (see diagram below).

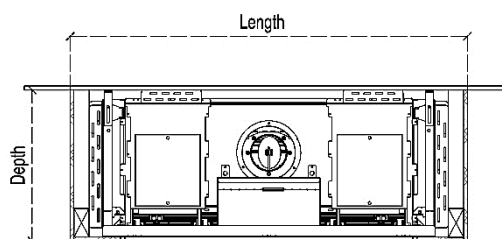

Fireplace Cavity (Top View)

Fireplace Series	Maximum Ledge Surface Area
Wilderness	$A \times B \leq 2200 \text{ sq. cm.}$

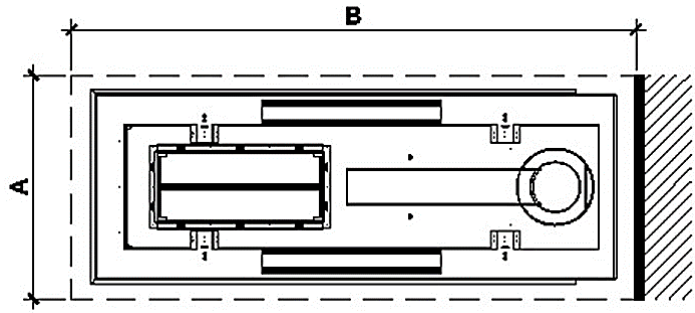

A = ledge depth, B= ledge width (Top View)

Oversized Partial Ledge

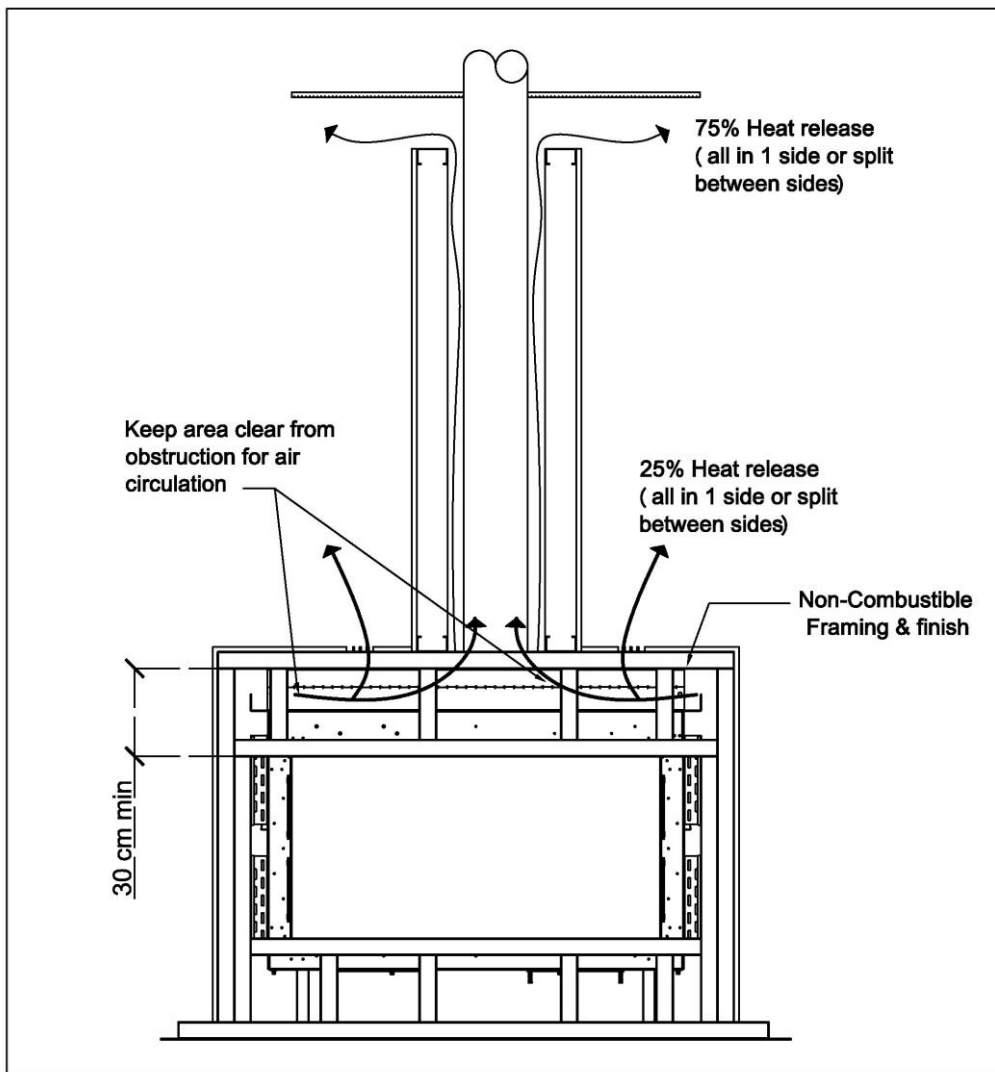

Oversized Partial Recessed Ledge Detail

! NOTE: Cavity area minimum requirements must be met throughout the entire fireplace cavity. See "Cavity Area Minimum" section above for details.

Step-by-Step Cavity Construction

The following checklist is a simplified overview of typical Cavity construction for a built-in fireplace installation. This list is not exhaustive and does not supplement thorough review of the installation manual.

Step 1

BUILD BACK AND SIDE WALLS

- ☑ Frame the back and side walls according to framing requirements.
- ☑ Build the platform (if necessary) to the desired height and install inside fireplace Cavity.
 - Platform must be stable and able to bear the full weight of the fireplace. Platform can be constructed out of wood, concrete, metal, or any other solid materials. Material is not required to be non-combustible.

Step 2

INSTALL FIREPLACE AND FLUEING, RUN GAS AND ELECTRICAL

- ☑ Install the fireplace and flueing. This must be completed by an authorized Ortal dealer (unless otherwise authorized by Ortal with written approval).
- ☑ Move the gas valve and receiver unit to the designated access panel location. If the fireplace will not have an access panel, keep gas valve and receiver unit directly underneath the fireplace.
- ☑ Run gas and electric to the gas valve and receiver unit location.

Step 3

BUILD FRONT WALL

- ☑ Install front Cavity wall:
 - Build front wall according to framing requirements.
 - Stand up the front wall and move into place.
 - Secure front wall to the rest of the Cavity structure.
- ☑ Cover the exterior of each wall (sides and front, and back if applicable depending on your design) with 9 mm Cement Sheet (or equivalent) and seal gaps with a non-combustible fire sealant.



NOTE: 9 mm Cement Sheet (or equivalent) is not required on the exterior portion of an insulated outside-facing wall.

- ☑ Check to make sure constructed Cavity meets heat release and air intake (if applicable) requirements.

Step 4

APPLY FINISHES

- ☑ Apply finishes and install accessories, following all clearances and building requirements.
- ☑ Ensure furniture and other combustible materials maintain a minimum 90 cm of clearance directly in front of the fireplace viewing area for both front and side viewing areas (as applicable).

Cold Climate Insulation

Seal all cracks around your appliance with non-combustible material and wherever cold air could enter the room. It is especially important to insulate outside cavity between fastenings, and under the floor on which the appliance rests if the floor is above ground level. Gas line holes and other openings should be caulked or stuffed with un-faced fiberglass insulation.

If the fireplace is being installed on a cement slab, a sheet of plywood or other raised platform can be placed underneath to prevent cold transfer to the fireplace and into the room. It also helps to sheetrock inside surfaces and tape and caulk fire stops for maximum air tightness.

Finishing

The following diagrams show various finish applications. **Diagrams apply to both combustible and non-combustible finish material.**

! IMPORTANT NOTES:

- All recessed installations must comply with applicable maximum overhang limit and side wall clearances. See “Maximum Overhang Depth” and “Clearance to a Side Wall” sections for details.
- No material is permitted to extend past the metal lip surrounding the fireplace viewing area. This area must be unobstructed to allow the heat barrier and inside glass panel to be removable.
- MANUFACTURED STONE: A minimum 5 cm recess is suggested. Consult stone manufacturer for clearance requirements.

! WARNING: Wood finish or floor/hearth extension may dry out, crack, warp or become discoloured over time. Consult with floor manufacturer for required clearances to a heat source.

Flush Installation

Diagram applies to both combustible and non-combustible finish material.

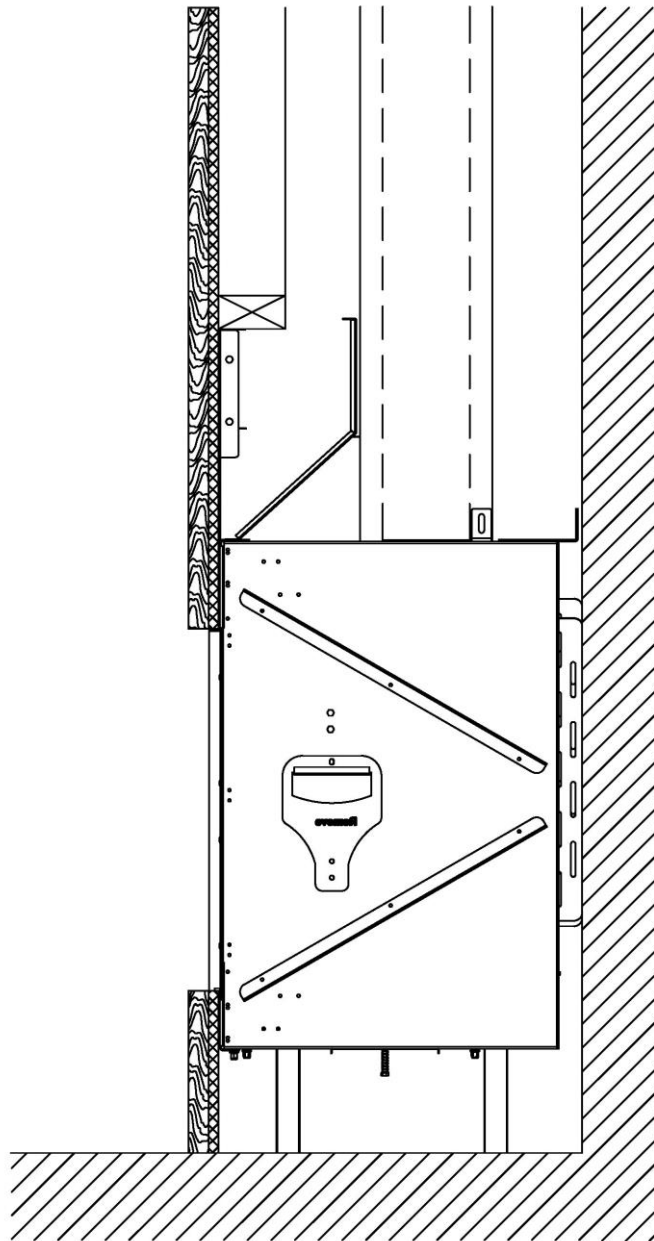

Recessed Installation

Diagram applies to both combustible and non-combustible finish material. The finish must maintain at least a 0.4cm clearance to the fireplace.

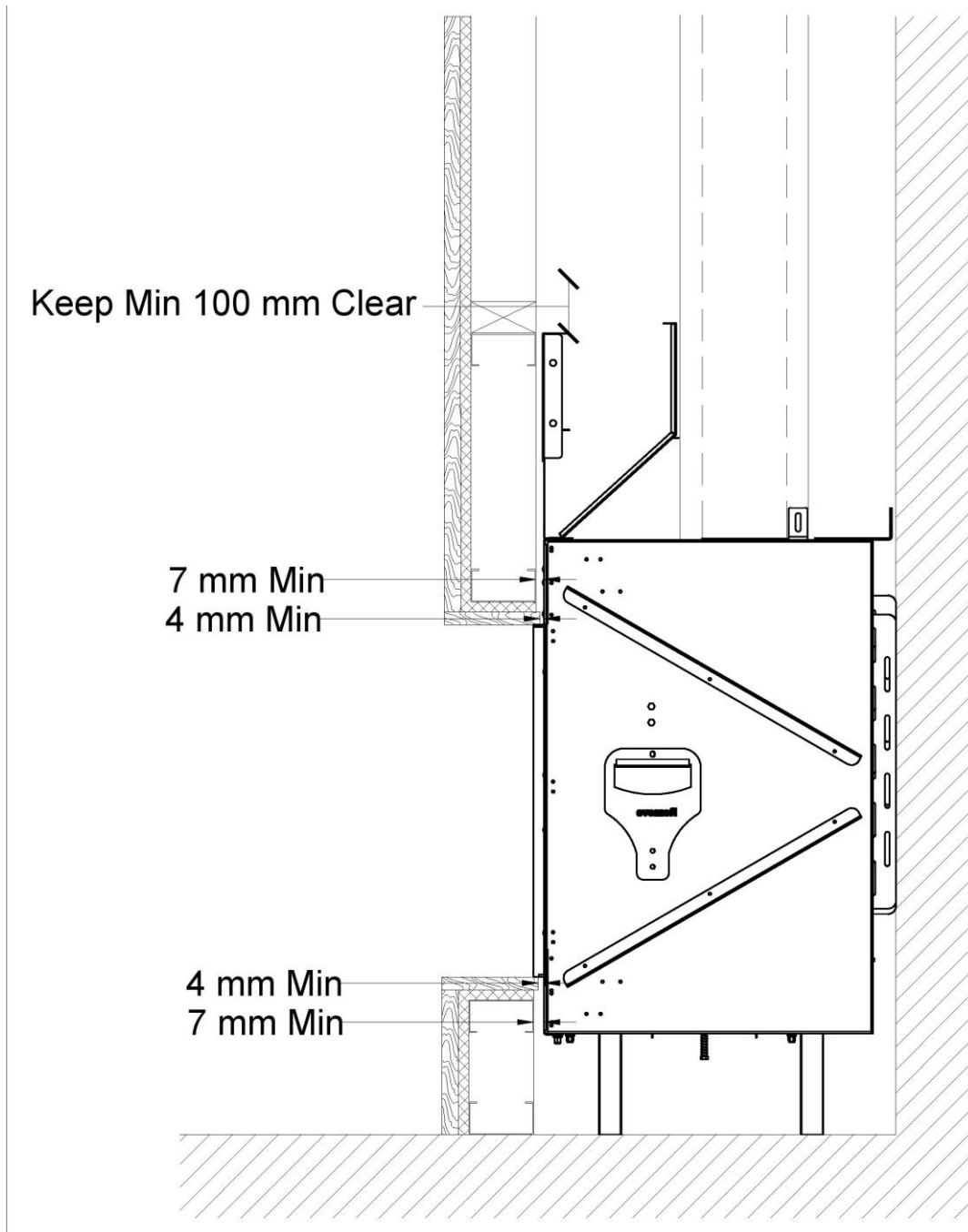

Gas Pressures

Fireplace Series	Burner Size	Gas Type	Inlet Pressures (kPa)		Test Point Pressure (kPa)	Gas Consumption (Mj/h)	Orifice Sizes*
			Min	Max			
Wilderness	Wilderness 70-3	Natural Gas	1.13	3.0	0.73	46	Left log – 800 Middle log - 320 Right log – 650 Main burner – 650
		Propane	2.75	3.0	1.6	46	Left log – 120 Middle log - 60 Right log – 120 Main burner - 220

 **NOTE:** It can take up to 20 minutes for the flames to turn yellow.

Routing the Gas Line

Correctly size and route the gas supply line from the supply regulator to the area where the access panel is located (or to the burner area if no access panel is available), as per the requirements outlined in the latest edition of the National Gas Regulatory in Australia.

The gas and electrical components are attached to the pilot on a flexible gas line and can be kept directly under the fireplace or moved to the side or back of the fireplace within 92 cm of the pilot (located at the centre front of the burner). Gas line should be routed to the access panel area (see “Access Panel” section for details). If no access panel is planned, gas line should be routed to the most accessible area within the 92 cm radius (as shown in diagram below).

A gas shut-off valve and a 30 cm gas flex connector are provided with every fireplace. The location of the gas shut-off valve is dependent on local codes and requirements. Check with your authority having jurisdiction for more information.

⚠ WARNING: The main gas valve must be installed to allow complete disconnection of the fireplace from the gas supply piping system for servicing purposes.

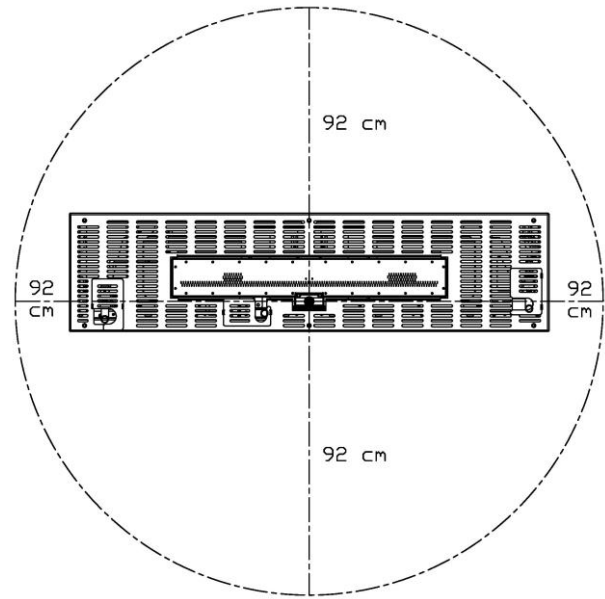

Correctly size and route the gas supply line from the supply regulator to the area where the appliance is to be installed.

⚠ WARNING –The main gas valve must be installed to allow complete disconnection of the appliance from the gas supply piping system for servicing purposes.

Control Connections

For information on remote and electronic systems, please visit the manufacturer’s website:

<http://www.mertikmaxitrol.com/>

Gas and Electrical Components

Assemblies and components are listed and described in the tables following the figure.

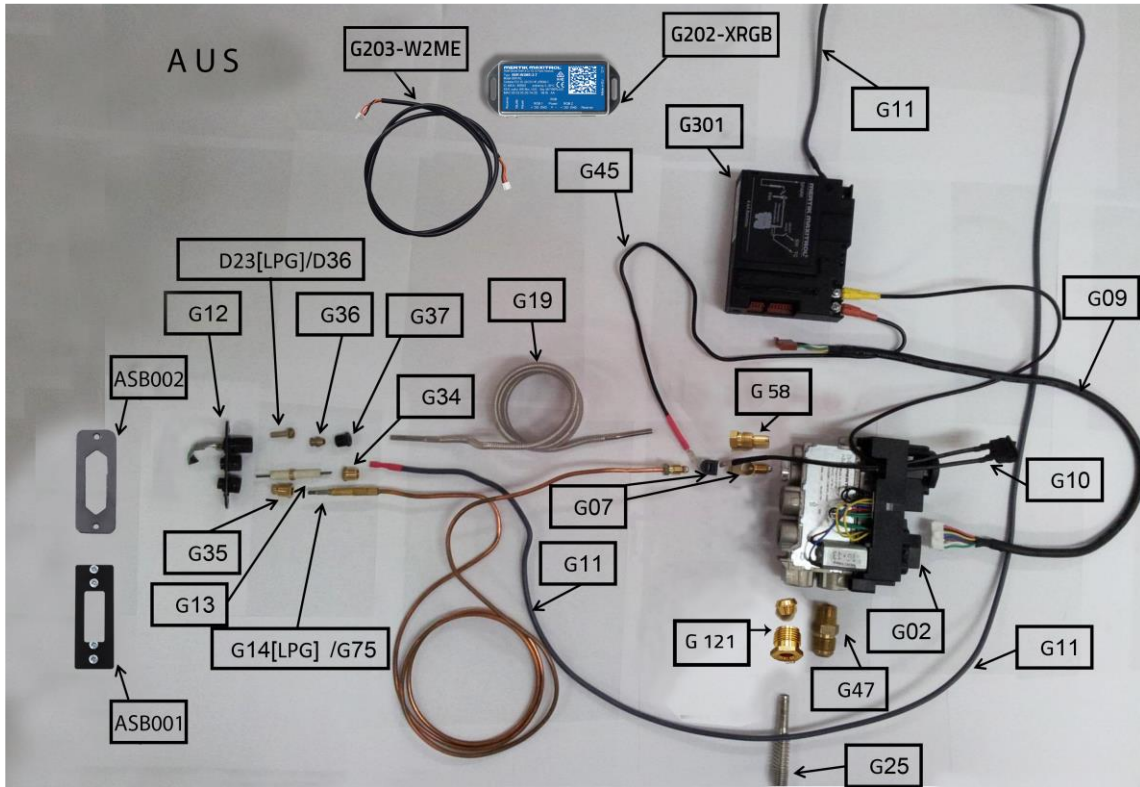

Part Number	Description
ASB001	Pilot Bracket
D23	Orifice LPG
D36	Orifice NG
G02	Mertik Gas Valve
G301	Symax Receiver
G202-XRGB	Symax Wi-Fi Box
G203-W2ME	Symax Wi-Fi Box Cable
G07	Thermocouple Block
G09	Wire Harness for Receiver and Gas Valve
G10	Switch w. cables 180/500 mm
G11	Spark Wire
G12	Pilot Base
G75	Thermocouple NG
G14	Thermocouple LPG

Part Number	Description
ASB002	Pilot Gasket
G13	Electrode Target Type
G121	Main Burner Gas Fitting
G25	Burner Gas Tube
G19	Pilot Gas Tube
G34	Spark Plug Connector
G35	Thermocouple Connector
G36	OLIVE D.4 Pilot gas tube compression ring valve
G37	Pilot gas tube fitting burner side
G38	Pilot Assembly Gasket
G45	Red Cable
G58	Connection fitting 4mm One-piece
G47	Fitting for main line inlet to gas valve GV60

The manufacturer of Ortal’s gas and electrical components is Mertik Maxitrol. For information on these components, please visit the manufacturer’s website: www.mertikmaxitrol.com

Gas Conversion

ORTAL fireplaces are closed room sealed systems that can operate with natural gas (NG) or (Universal LPG). The following sections present detailed information about gas routing, pressures, conversion, maintenance and more:

To change the gas source of a fireplace, you need to request a gas conversion kit. Gas conversion can be performed only by technicians who have specific authorization to change these components. The actual change must be done by the authorized technician. Not all installers are authorized to provide gas conversion services.

The following procedure is a guide for NG-LPG conversion.

⚠ WARNING: Before starting this procedure, make sure to disconnect the main gas supply to the unit.

NATURAL GAS TO LP CONVERSION for Wilderness Series

⚠ WARNING: For conversion from LPG to NG, follow the same steps and make sure to use LPG parts shown in these instructions.

TOOLS NEEDED:

8,9,10,12,15,17mm wrench - 10mm t-handle - #3 Phillips -#2 Phillips - 3mm and 2mm Flat screwdriver – Manometer - Bubble solution - Suction cup - Red paint pen - 5mm ball end Allen - 2.5 Allen key

PARTS NEEDED:

Pilot set-LP/NG, Burner orifice from current chart , NG/LP log orifice , NG/LP log set

1. Remove glass.
2. Remove the media tray.
3. Disconnect the gas tube from the log base, remove the natural gas orifice and replace it with the correct size LP orifice based on the most current conversion chart.

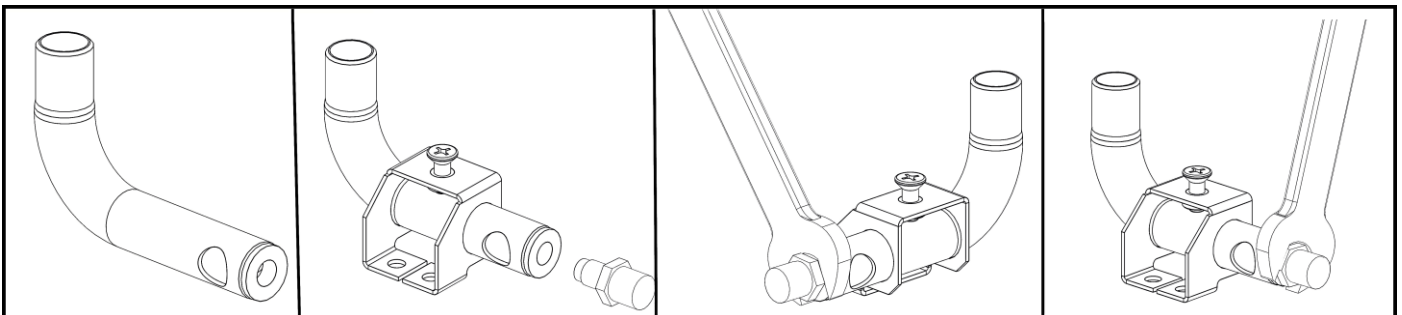

4. Replace the NG log base with LPG log base
5. Remove the pilot hood and screws so the pilot can be removed
6. Remove the burner, pull the pilot out
7. Disconnect the pilot assembly from the valve and receiver
8. Disconnect the gas tube from the burner, remove the natural gas main burner orifice and replace with the correct size LP orifice based on the most current conversion chart.
9. Loosen the 8mm bolts on the burner and open the air shutter all the way, tighten the bolts
10. Replace the natural gas pilot assembly with PILOT SET-LP. Ensure the pilot orifice and thermocouple are correct and pilot gasket is in place
11. Reconnect the gas tube and put the burner back in. Ensure all the bolts are tight, put the media tray back in place and secure
12. Put the ceramic glass back on

Reconnect the pilot to the valve and receiver

Connect the fireplace to the LP source and to a power source

Turn the fireplace on. Check the input and manifold pressures, adjust as needed based on the most current conversion chart

Inspect the pilot flame; adjust as needed for flame to contact the thermocouple and ignition port on burner

Check all gas connections for leaks

Remove the original markings on the rating plate and re-mark based on what burner is in place. Mark plate LP in red paint marker

Disconnect the gas, repackage

<u>Burner</u>	<u>NG injectors</u>	<u>LPG injectors</u>
Driftwood Valley Oak Birch	Left log – 800 Middle log - 320 Right log – 650 Main burner – 650	Left log – 120 Middle log - 60 Right log – 120 Main burner - 220
Test Point Pressure	0.73 kPa	1.6 kPa

The kit includes: LP Pilot set, Burner orifice from current chart, LP log orifice, LP log set

<u>Part description</u>
Conversion kit NG to LPG for Driftwood
Conversion kit LPG to NG for Driftwood

Pilot and Thermocouple Maintenance

The pilot flame must be visually checked. The pilot flame has two distinct flames. One engulfs the thermocouple, and the other reaches the main burner. Both flames must be present.

The area around the injector should be inspected. Any foreign material must be removed with a brush or vacuum.

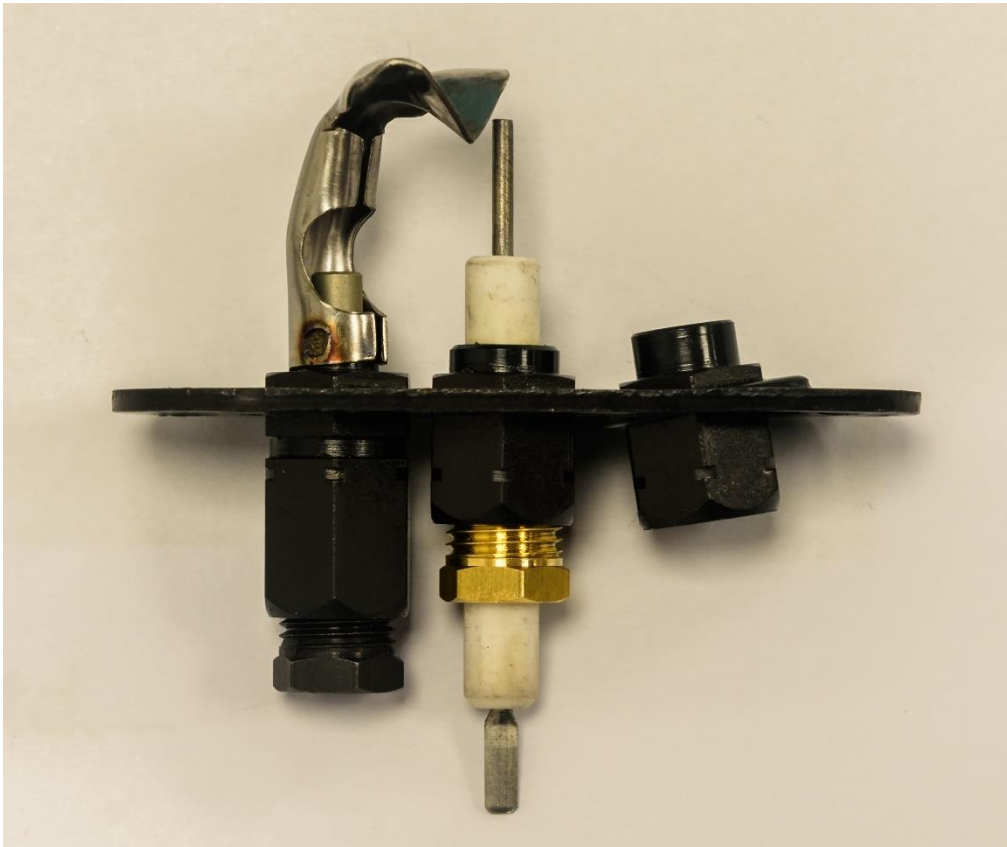

Figure 1: Thermocouple Injector

 **Always be present when the fireplace is in operation.**

Thermocouple Maintenance

Thermocouple integrity and operation must be checked. The installer needs to confirm that the thermocouple is in place, and is not cracked or damaged.

General Flue Requirements

The fireplace operates using a direct flue system and requires co-axial direct flue pipe. The fireplace must be properly connected to an approved flue system. Flueing is not provided with the fireplace and must be sourced from one of the approved flue manufacturers mentioned in the table below. Proper installation, use, and maintenance of flueing is determined by and can be acquired from the flue manufacturer.

Flue Requirements			
Fireplace Series	Direct Flue Type	Flue Size	Approved Flue Manufacturers
Wilderness 90 H/HH FR/RS/LS/TS/TU Wilderness 110 H/HH FR/RS/LS/TS/SA/TU Wilderness 130 H/HH FR/RS/LS/TS/TU Wilderness 150 H/HH FR/RS/LS/TS/SA/TU Wilderness 170 H/HH FR/RS/LS/TS/TU Wilderness 200 H/HH FR/RS/LS/TS/TU Wilderness Traditional 90 Wilderness Traditional 110	Ortal Power Flue	100/150 co-axial direct flue pipe	DuraVent

 **TERMINATION CAP NOTE:** Low Profile Vertical Termination Cap and Sconce Horizontal Termination Cap can negatively impact flame appearance and are not recommended for use with the fireplace.

 **WARNING:** Do not combine flue components from different flue manufacturers. Please follow the manufacturer's instructions for flue system installation.

Power Flue Installation

! Please refer to ORTAL Power Flue Manual for the installation of the Power Flue.

The Ortal Power Flue System have been tested for safety and efficiency for use with Ortal fireplaces.

! **IMPORTANT – PLEASE READ:**

- It is the responsibility of the fireplace dealer and installer to ensure that the Power Flue and components are installed in compliance with these instructions and all applicable codes.
- Before starting, take careful note of **ALL** the **WARNINGS** in this manual.
- Consult the authority having jurisdiction to determine the need for a permit prior to starting the installation.

Pre installation Considerations

IMPORTANT: Read Before You Begin
Maximum Flue Run: Maximum flue run distance is 50 meter. Each 90° elbow in the run reduces run by 2 meters
Vertical Drop: Flue configuration cannot exceed 6 meter of cumulative vertical drop (downhill run). For Flueing that rises vertically after a drop, condensation drainage must be installed mid-way through the horizontal portion of the drop.
Elbows: Up to twelve 90° elbows is permitted. Each 90° elbow reduces run length by 2 meters.
Condensation Drainage: For flue configurations that exceed 20 meters, install a condensation drain at the lowest point of the flue run after the 20-meter point. More than one condensation drain may be required if the flue run has a vertical drop after the 20-meter point in the run.
Clearances: Plan for clearances around the pipe are met. Due to airflow considerations, it will not be possible to keep only 50 mm of clearance on every side. To keep the component operating temperature cool, one of the following conditions must be met: <ul style="list-style-type: none">▪ Power Flue must be located in an area with a min. 1 cubic meter of air space.-OR-▪ Power Flue must be located in an area with a min. 0.226 cubic meters of air space AND the access panel must be louvered to allow for a net min. 500 square cm of air space.
Flue Installation: For flue component installation instructions, refer to manufacturer's instructions for gas appliances.
Flue Pipe Connections: <ul style="list-style-type: none">▪ Must be intact and without flaw (i.e., no holes, tears, open seams, corrosion, or other issues that may inhibit the proper function of the Power Flue System).▪ Inner and outer gasket rings must be intact.▪ Each connection between all the Flueing components must be securely locked.▪ Alignment dimples on the pipe must be correctly aligned. Twist pipe in place to secure, as per manufacturer's instructions.
Sealing: <ul style="list-style-type: none">▪ Failure to properly seal the Flueing can prevent the system from working properly and can result in damage to the fireplace and/or surrounding building material.▪ Damaged seals may cause pressure loss.

Flue Clearances

The following clearances apply to the flue system regardless of flue manufacturer.

<input checked="" type="checkbox"/> Flue Clearances	
<input checked="" type="checkbox"/> Sides: 25 mm	<input checked="" type="checkbox"/> Applies to entire circumference when flueing is oriented vertically .
<input checked="" type="checkbox"/> *Top: 75 mm	<input checked="" type="checkbox"/> Applies to flueing with any amount of horizontal aspect.
<input checked="" type="checkbox"/> Bottom: 25 mm	<input checked="" type="checkbox"/> Applies to flueing with any amount of horizontal aspect.

***Exception:** Wall thimble top clearance to any material is **25mm**.

Flue Installation and Clearances

When installing the flueing, be sure that the flue pipe is supported by the structural surrounding and not by the firebox. Secure the flue connection to the fireplace with a minimum of 3 self-tapping screws. Each elbow should be strapped to reduce movement or possible disconnection. Follow the instructions of the flue system manufacturer.

Vertical Clearance Diagram

Minimum Height From Roof To Lowest Discharge Opening

Roof Pitch	H (Min.) cm.
Flat to 6/12.....	30*
Over 6/12 to 7/12.....	38*
Over 7/12 to 8/12.....	46*
Over 8/12 to 9/12.....	61*
Over 9/12 to 10/12.....	76*
Over 10/12 to 11/12.....	99
Over 11/12 to 12/12.....	122
Over 12/12 to 14/12.....	152
Over 14/12 to 16/12.....	182
Over 16/12 to 18/12.....	213
Over 18/12 to 20/12.....	229
Over 20/12 to 21/12.....	244

*H min. may vary depending on regional snowfall. Refer to local codes.

Staggered Termination Caps

A	B
15 cm. (minimum) up to 61 cm.	46 cm. minimum
61 cm. and over	0 cm. minimum

* If using decorative cap cover(s), this distance may need to be increased. Refer to the installation instructions supplied with the decorative cap cover.

** In a staggered installation with both gas and wood or fuel oil terminations, the wood or fuel oil termination cap must be higher than the gas termination cap.

NOTE: This chart does not apply to a chimney shroud application. See the “Chimney Shroud” section on the following pages for more information.

TERMINATION CAP NOTE: A Low Profile Vertical Termination Cap can negatively impact flame appearance and is not recommended for use with the fireplace.

FLUE TERMINATIONS

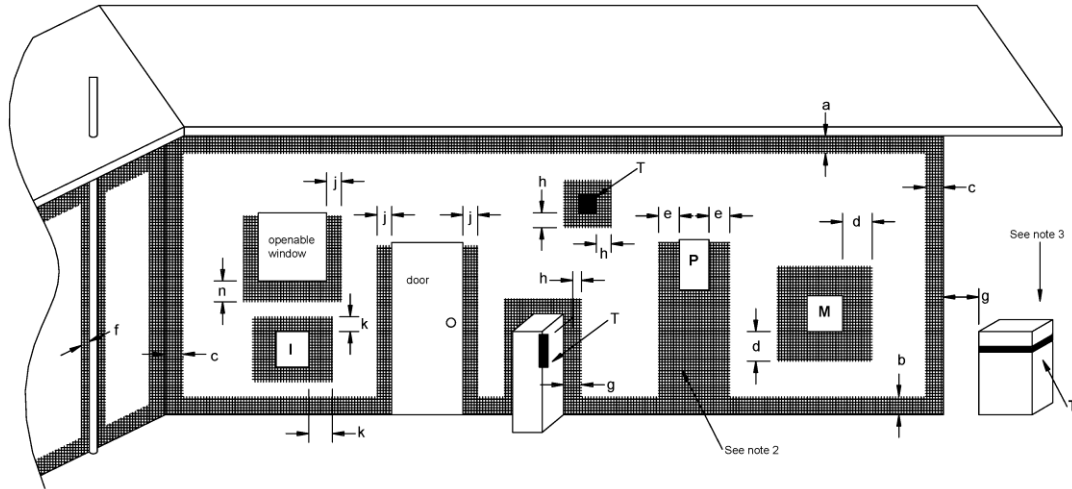

T = Flue terminal
 I = Mechanical air inlet
 M = Gas meter
 P = Electricity meter or fuse box
 Shading indicates prohibited areas for flue terminals

- | | | |
|---|----------------------------------------------------------------------------------------------------------------------------------------------------------------------------------------------------|-----------------------------------|
| a | - Below eaves, balconies or other projections:
Appliances up to 50 MJ/h input..... | MIN. CLEARANCE (mm)
300 |
| | Appliances over 50 MJ/h input..... | 500 |
| b | - From the ground or above a balcony..... | 300 |
| c | - From a return wall or external corner..... | 500 |
| d | - From a gas meter (M)..... | 1000 |
| e | - From an electricity meter or fuse box (P)..... | 500 |
| f | - From a drain or soil pipe..... | 150 |
| g | - Horizontally from any building structure (unless appliance approved for closer installation) or obstruction facing a terminal..... | 500 |
| h | - From any other flue terminal, cowl, or combustion air intake..... | 500 |
| j | - Horizontally from an openable window, door, non-mechanical air inlet, or any other opening into a building, with the exception of sub-floor ventilation:
Appliances up to 150 MJ/h input..... | 500 |
| | Appliances over 150 MJ/h input..... | 1500 |
| k | - From a mechanical air inlet, including a spa blower..... | 1500 |
| n | - Vertically below an openable window, non-mechanical air inlet or any other opening into a building, with the exception of sub-floor ventilation..... | See table below |

CLEARANCE			
Space Heaters	All other appliances		
Up to 50 MJ/h input	Up to 50 MJ/h input	Over 50 MJ/h input and Up to 150 MJ/h input	Over 50 MJ/h input
6 in. (150 mm)	20 in. (500 mm)	39 in. (1000 mm)	59 in. (1500 mm)

- NOTES:**
- All distances are measured vertically or horizontally along the wall to a point in line with the nearest part of the terminal.
 - Prohibited area below electricity meter or fuse box extends to ground level.
 - See clause 5.13.6.6 for restrictions on a flue terminal under a roofed area.
 - See Appendix J, Figure J1(a) and J2(a) for clearances required from a flue terminal to a LP Gas cylinder. A flue terminal is considered to be a source of ignition.

MINIMUM CLEARANCES REQUIRED FOR BALANCED FLUE TERMINALS OR THE FLUE TERMINALS OF OUTDOOR APPLIANCES

Flue Terminations

Flue Maintenance

Regular inspection of the flueing system by an authorized service technician every six months is recommended. The following maintenance routing is recommended:

1. Inspect for excessive condensation, e.g., water droplets forming in the inner lining, and subsequently dripping from the joints. This can cause corrosion in the system.
2. Check for corrosion in areas exposed to the elements. Components with rust spots or holes must be immediately replaced.
3. Ensure that there is no foreign material in the flues. Survey by removing the cap and shining a light down the flue.
4. If possible, check all joints and pipes to make sure that nothing has been disturbed or loosened.

Chimney Shroud

Top Open

Keep a minimum **15 cm** clearance around the diameter of the cap's side edge and extending above and below the cap.

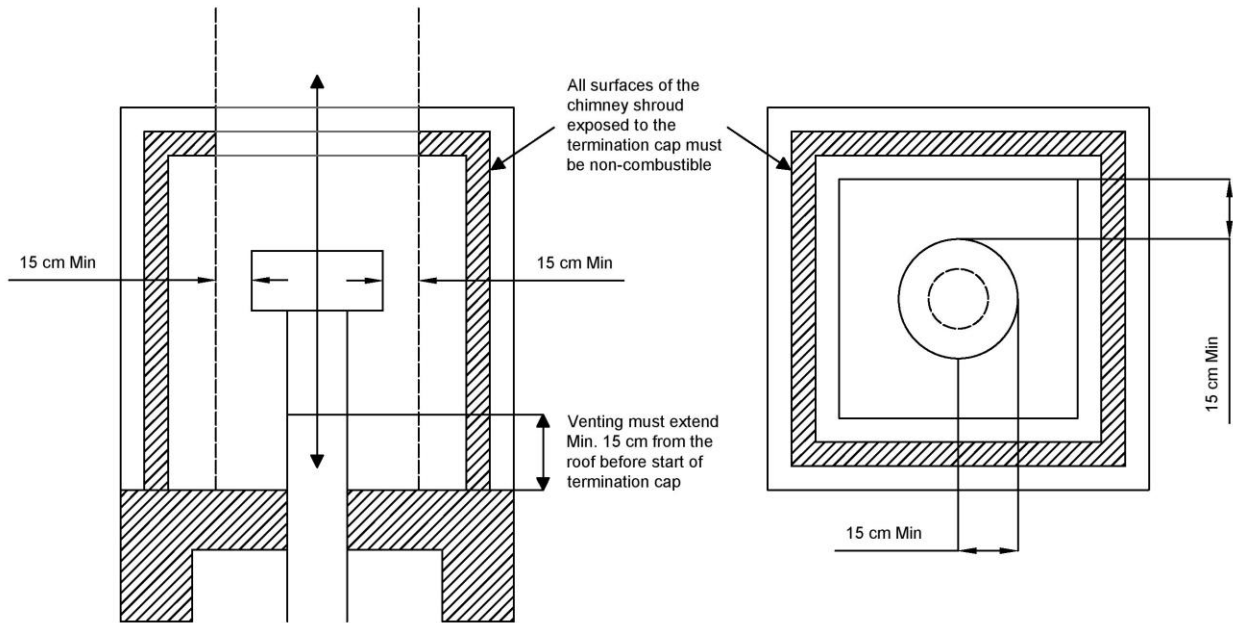

Sides Open

Keep a minimum **15 cm** clearance around the diameter of the cap's side edge, and a minimum **25 cm** clearance above the top of the cap. For openings in the shroud, make sure to allow enough airflow space to release the exhaust gases and allow the flue to operate properly.

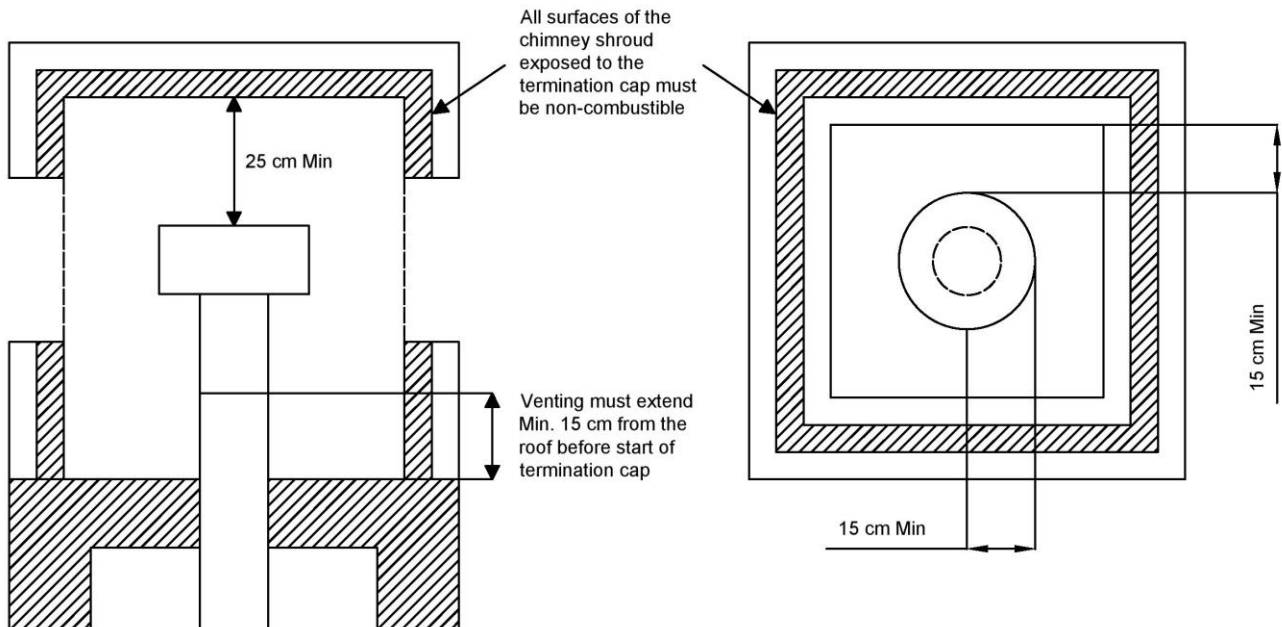

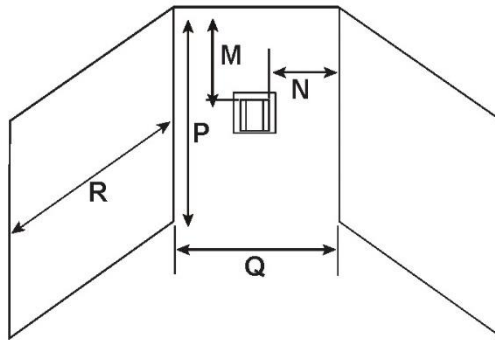

Covered Alcove: spaces open only on one side and with an overhang

Horizontal Termination Clearances Continued: Covered Alcove Application			
Location	Country	Minimum Clearance	Description
COVERED ALCOVE APPLICATION	M	40 cm	Clearance under non-vinyl veranda, porch, deck, balcony, or overhang. NOTE: Termination in a covered alcove space is permitted with the dimensions specified. 1. There must be 1-metre minimum between termination caps. 2. All mechanical air intakes within 3 metres of a termination cap must be a minimum of 1 metre below the termination cap. 3. All gravity air intakes within 1 metre of a termination cap must be a minimum of 30 cm below the termination cap.
	N	15 cm	Non-vinyl sidewalls.
		30 cm	Vinyl sidewalls.
	P	20 cm	Alcove height.
	Q	See table below.	Alcove width (dependent on number of caps in the space).
	R	See table below.	Alcove depth (dependent on number of caps in the space).

# Flue Caps	Q _{MINIMUM}	R _{MAXIMUM}
1 flue cap	1 metre	2 x Q _{ACTUAL}
2 flue caps	2 metres	1 x Q _{ACTUAL}
3 flue caps	3 metres	² / ₃ x Q _{ACTUAL}
4 flue caps	4 metres	¹ / ₂ x Q _{ACTUAL}
	Q_{MIN} = # flue caps x 3	R_{MAX} = (²/_{# flue caps}) x Q_{ACTUAL}

! HORIZONTAL TERMINATION CAP CLEARANCES - NOTES:

- If exterior walls are finished with vinyl siding, it is *required* that a vinyl protector kit be installed.
- Flue system termination is not permitted in screened porches.
- Flue system termination is permitted in porch areas with two or more sides open. You must follow all sidewalls, overhang and ground clearances as stated.
- Termination caps may be hot. Consider their proximity to doors or other traffic areas.

! TERMINATION CAP NOTE: Sconce Horizontal Termination Cap can negatively affect flame appearance and are not recommended for use with the fireplace.

Fireplace Heat Barrier

The glass fronts of the fireplace and surrounding surfaces can become extremely hot during and even long after operation. Touching the hot glass front can lead to serious burns. The fireplace heat barrier prevents contact with the glass front.

The heat barrier is constructed to maintain a fixed relationship between essential barrier parts and the outside glass viewing area. The barrier must be installed properly prior to start-up of the firebox.

ORTAL fireplace are fitted with **Double glass** barriers: Barriers made of inner and outer glass.



WARNING – The firebox MUST not be used without the heat barrier in place.

Removal / Assembly of the Double Glass Heat Barrier and Inner Glass

The procedure below shows how to remove the glass of new design double glass units. To re-install the glass, perform the steps in the opposite order.

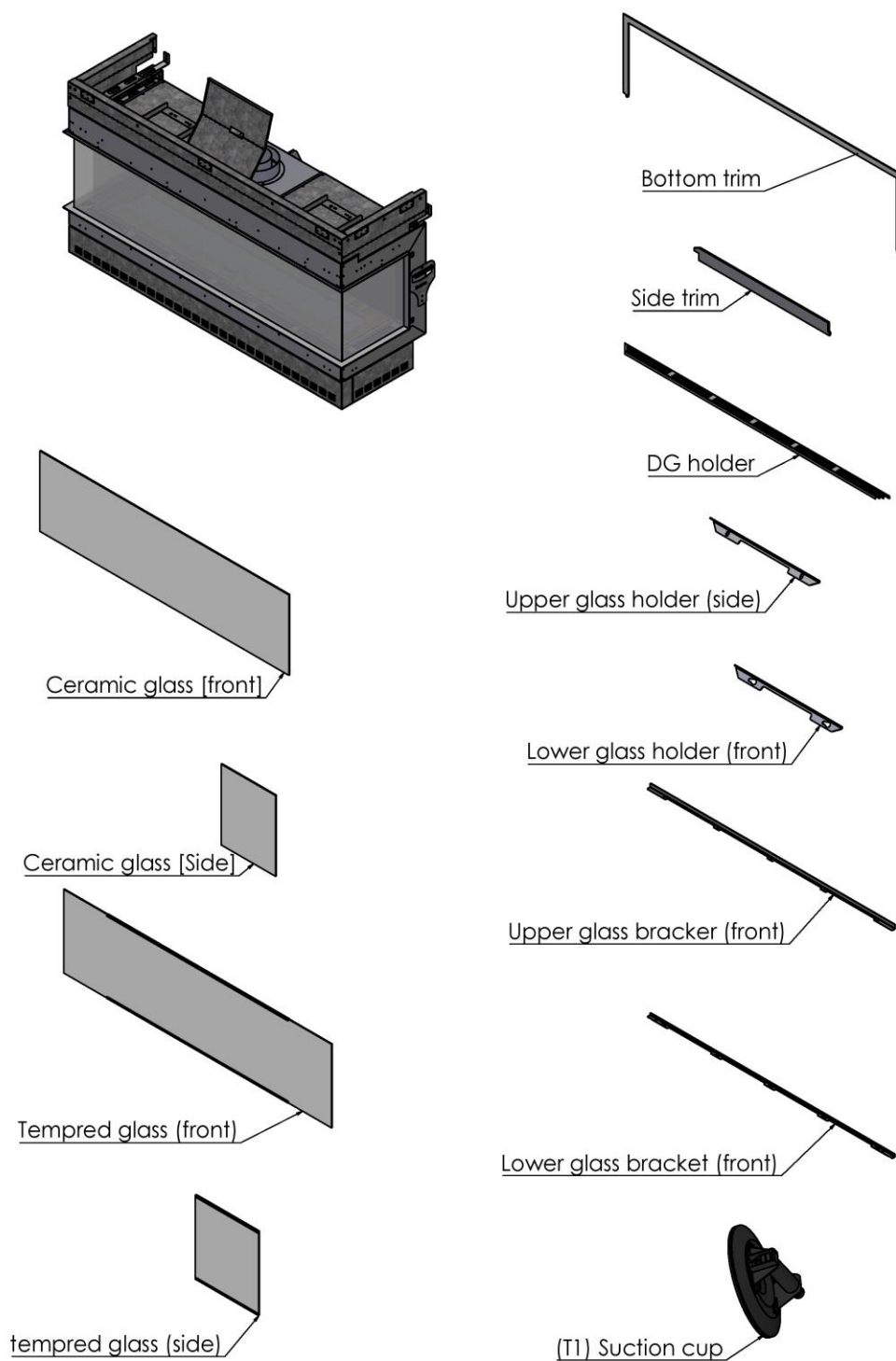
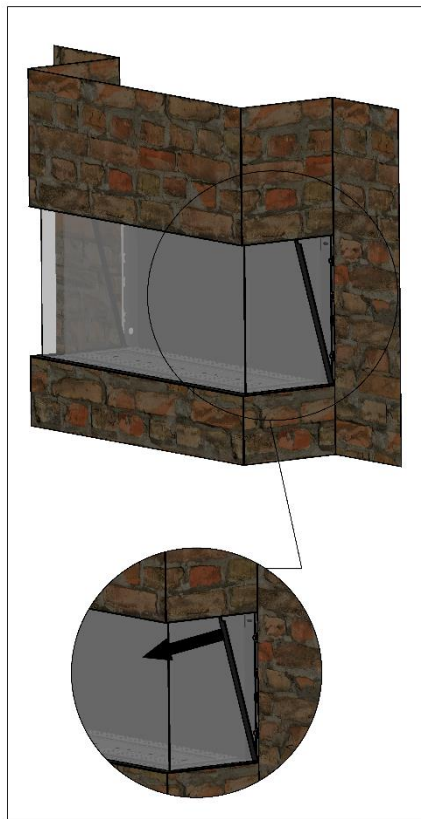

Figure 2: Double Glass Heat Barrier: Parts

To remove the double glass heat barrier:

1. Remove the side trim:

Hold the upper side of the side trim with your index finger, and pull it until it releases from the top magnet.



Continue pulling the side trim until it is disconnected from the bottom magnet.

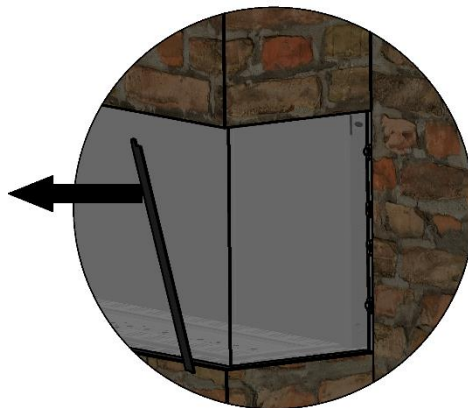

Repeat with the other side trim.

2. Remove the bottom trim:

Lift the end of the bottom trim with your index finger, and pull it up until it releases from the magnets.

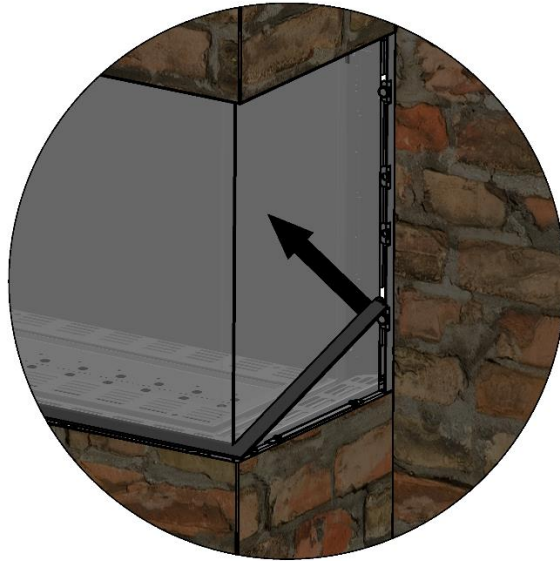

Then, pull the bottom trim all the way out.

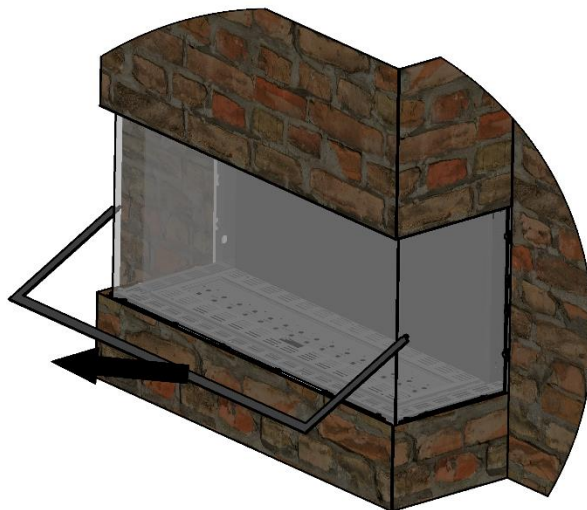

3. Remove the Double Glass holders:

Using a screwdriver, start removing the two screws from each of the front glass holders. Then take them all the way out.

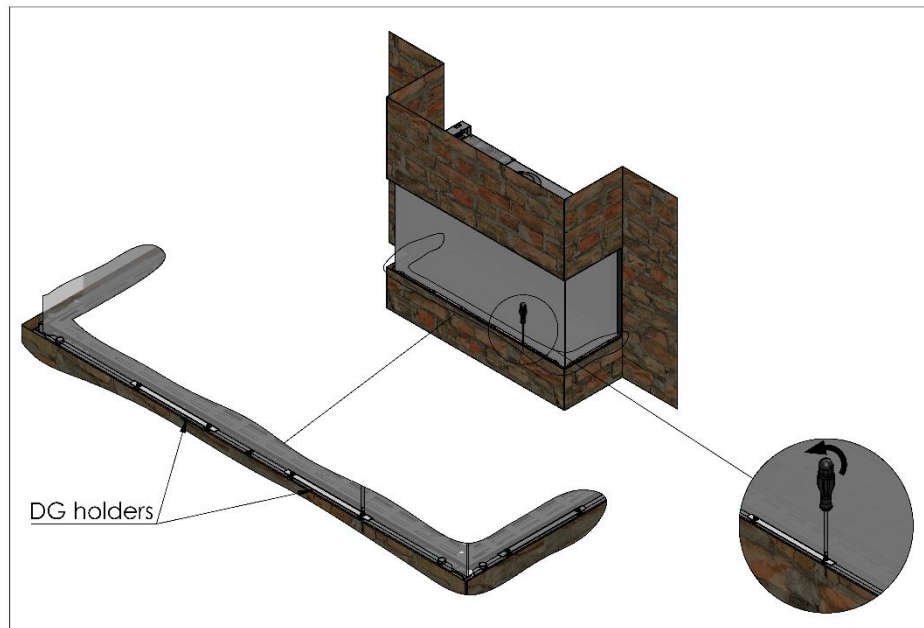

4. Remove the double glass:

Using the suction cup, hold the front glass from the centre and raise it until it reaches the top.

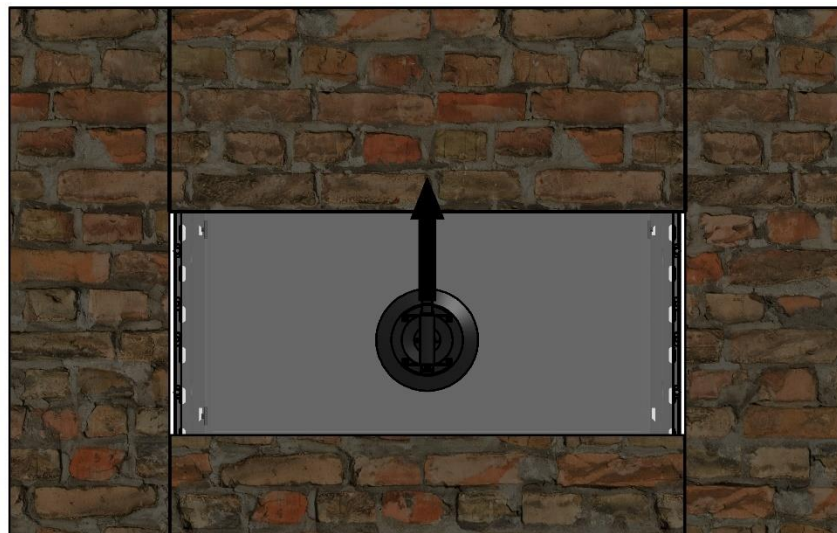

Pull the bottom of the glass as shown in the figure:

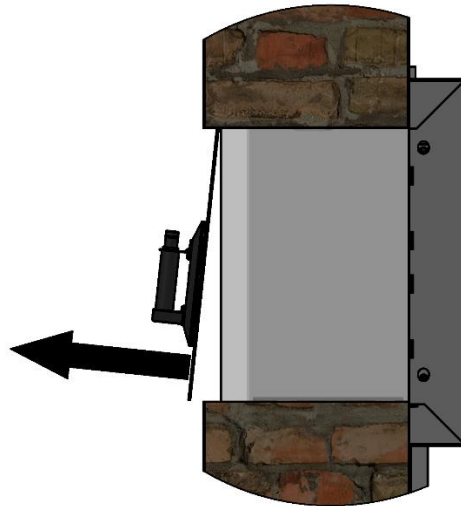

Pull the glass down, and take it out.

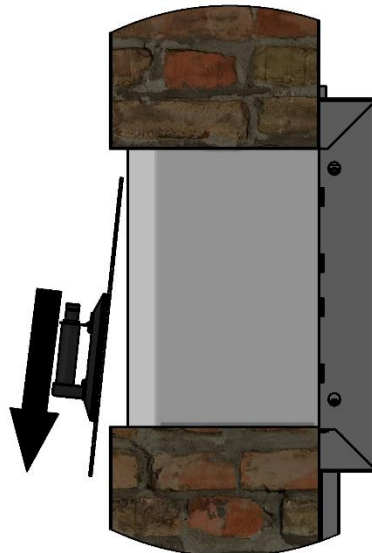

If necessary, repeat the procedure to remove the side glass.

5. Remove the double glass fan covers:

Pull each fan cover up until it is released.

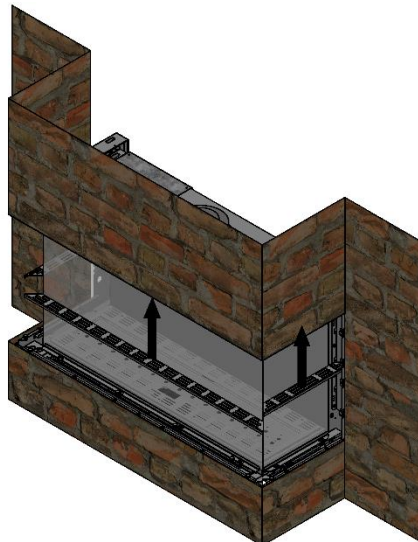

6. Remove the front glass brackets:

Using a suction cup, hold the front glass from the centre. While holding the glass, loosen the screws of the upper bracket.

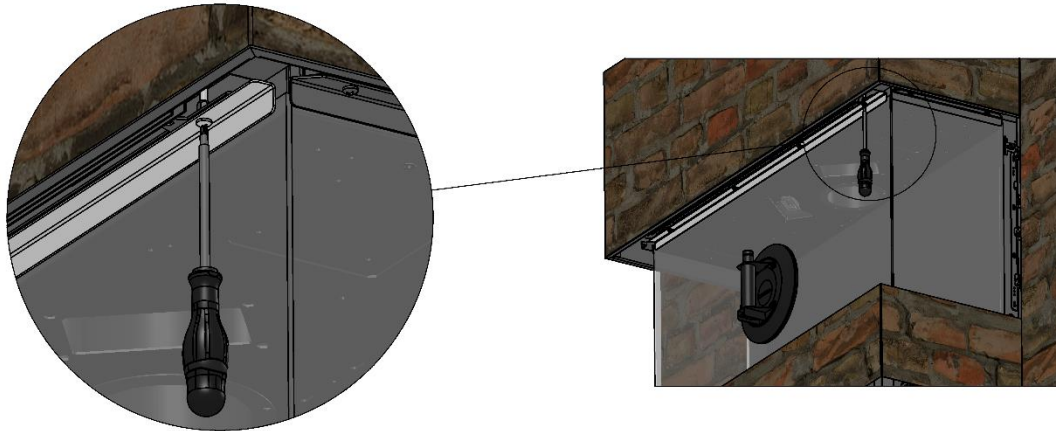

Take all the bottom bracket screws out. Then, remove the bracket.



7. Remove the glass:

Pull the suction cup up to lift the glass until it reaches the top.

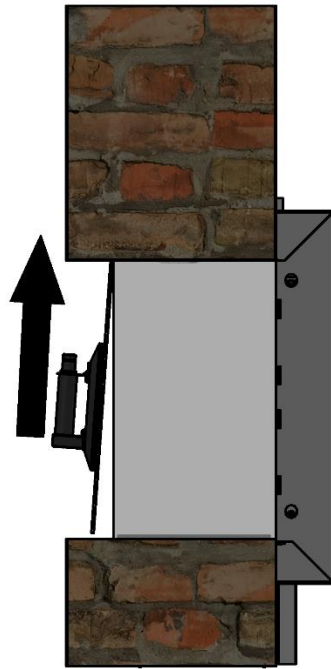

Pull the suction cup from the bottom until the glass clears the frame.

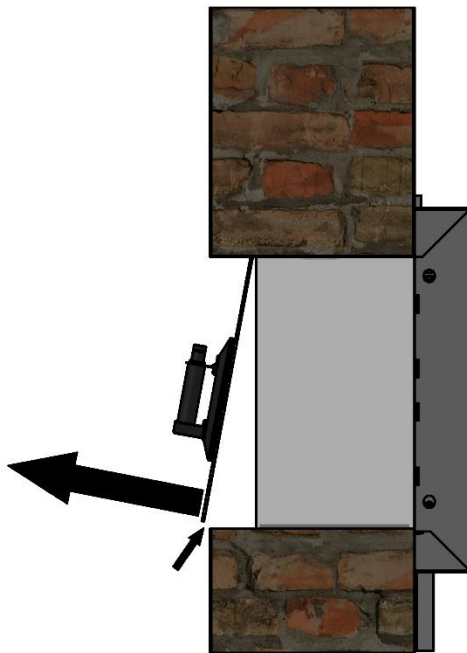

Pull the suction cup to take the glass all the way out.

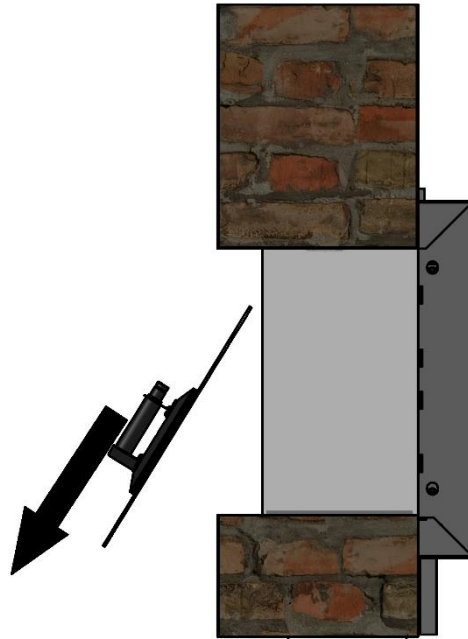

If necessary, remove the side glass by repeating Steps 6 and 7.

Removing/Assembling the Back Panel

The procedure below shows how to remove the back panel of the unit. The procedure is relevant for units that include a reflective panel or granite.

To re-install the panel, perform the steps in the reverse order.

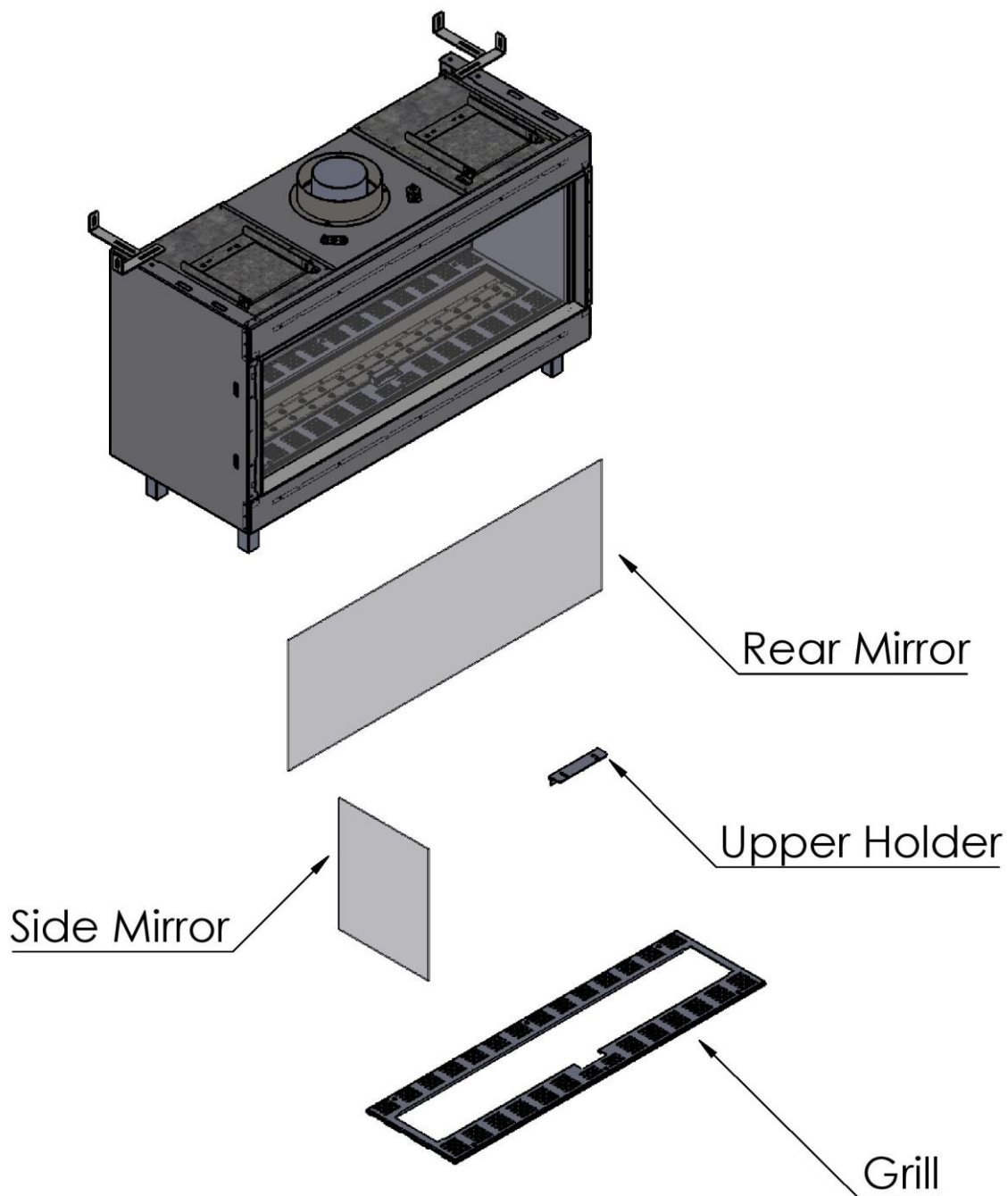
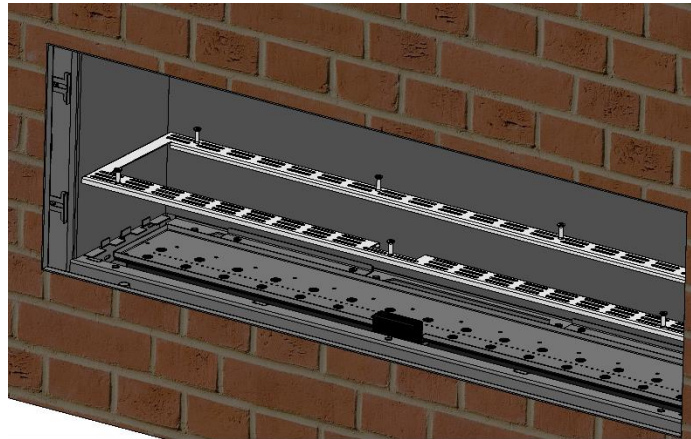

Figure 3: Back Panel: Parts

To remove the back panel:

1. Remove the front glass and the front heat barrier (Fireplace Heat Barrier on page 51)
2. Remove the grill screws. Lift the grill and pull it out.



3. Remove the upper panel holders:
Hold the panel, using a suction cup.

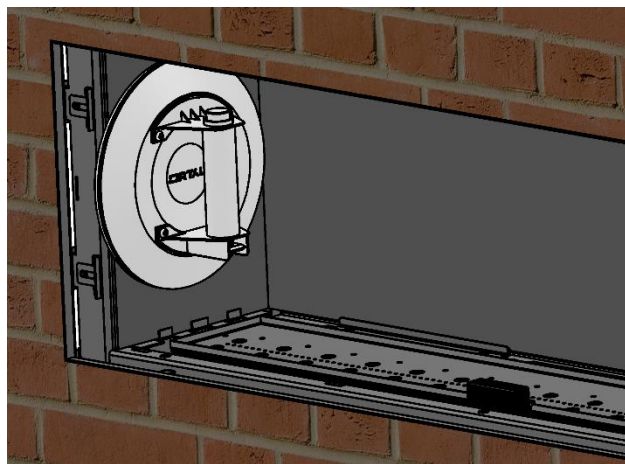

Remove the screws from each holder, and take the holders out.

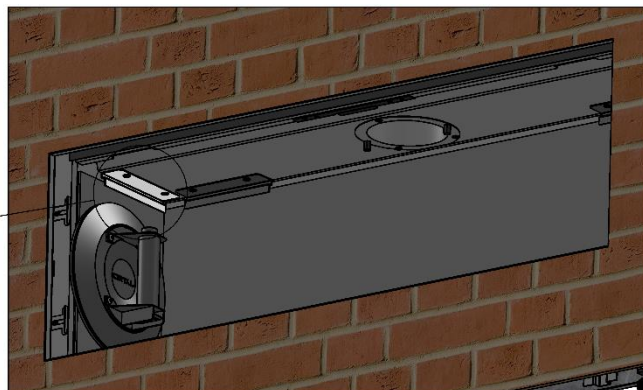
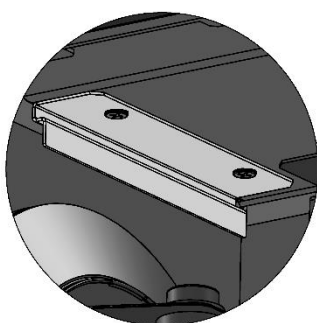

4. Remove the side panel:
Lift the panel up, as shown:

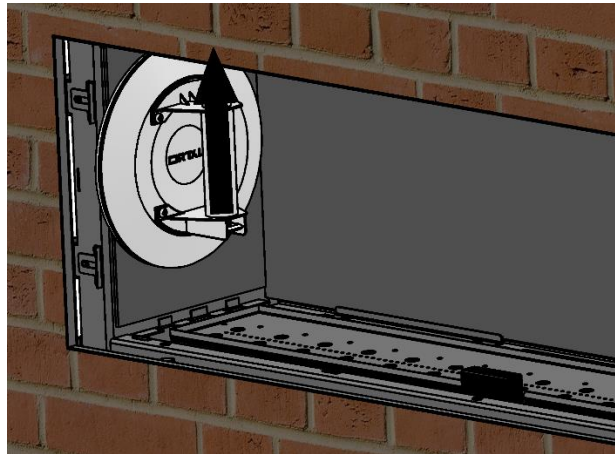

Tilt the panel from the bottom, and pull it towards the fireplace centre.

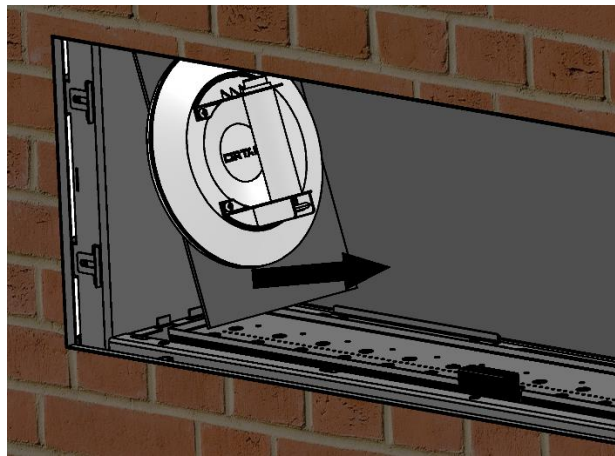

Pull the panel out and remove it.

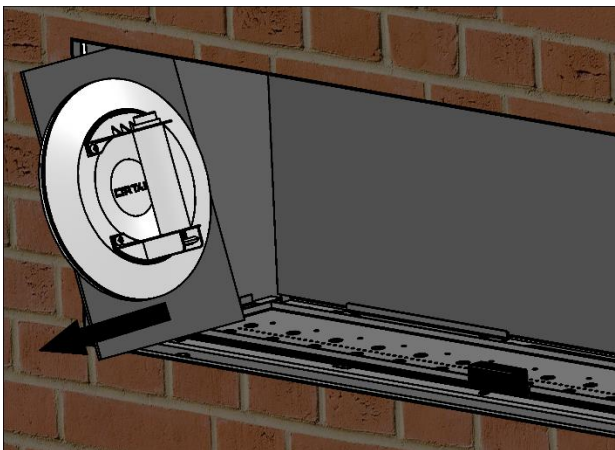

If necessary, remove the other side panel in the same manner.

5. Remove the rear panel:

Remove the bottom holders (if present).

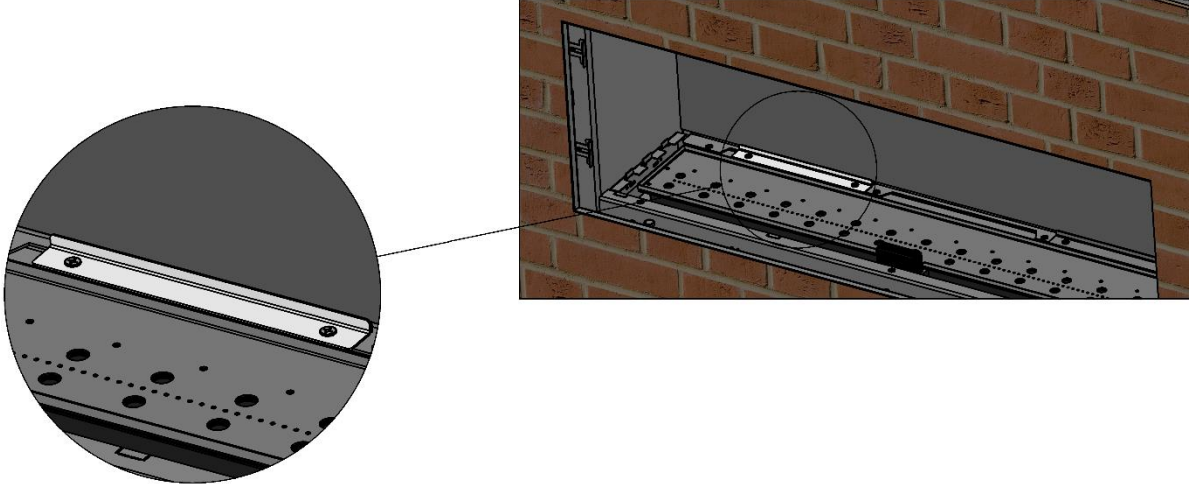

If the screws on the starter collar are type (M10), remove them as shown in the figure below.
Do NOT remove Phillips screws from the starter collar.

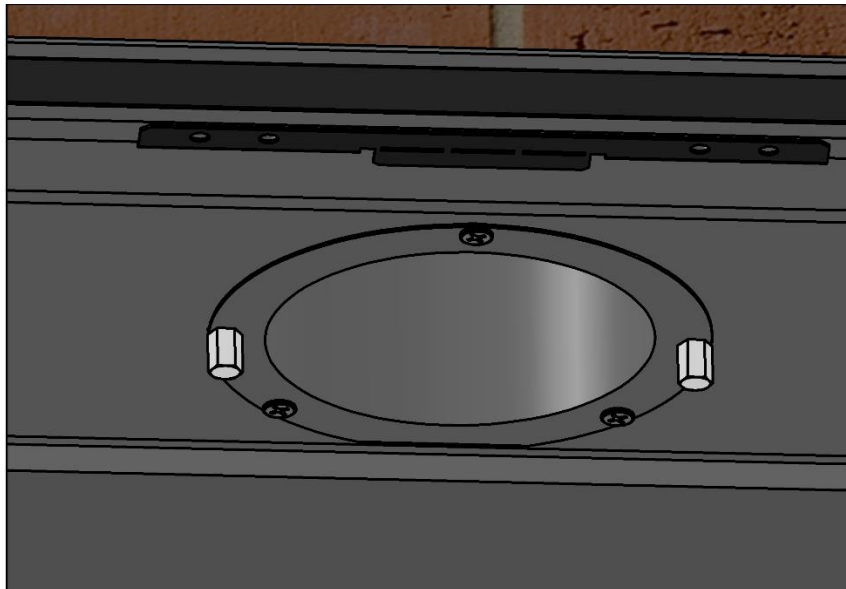

Remove the rear panel in the same manner as the side panel (see Step 4).

75/65 Front Bricks Installation

The following procedure provides guidelines for installing front bricks.

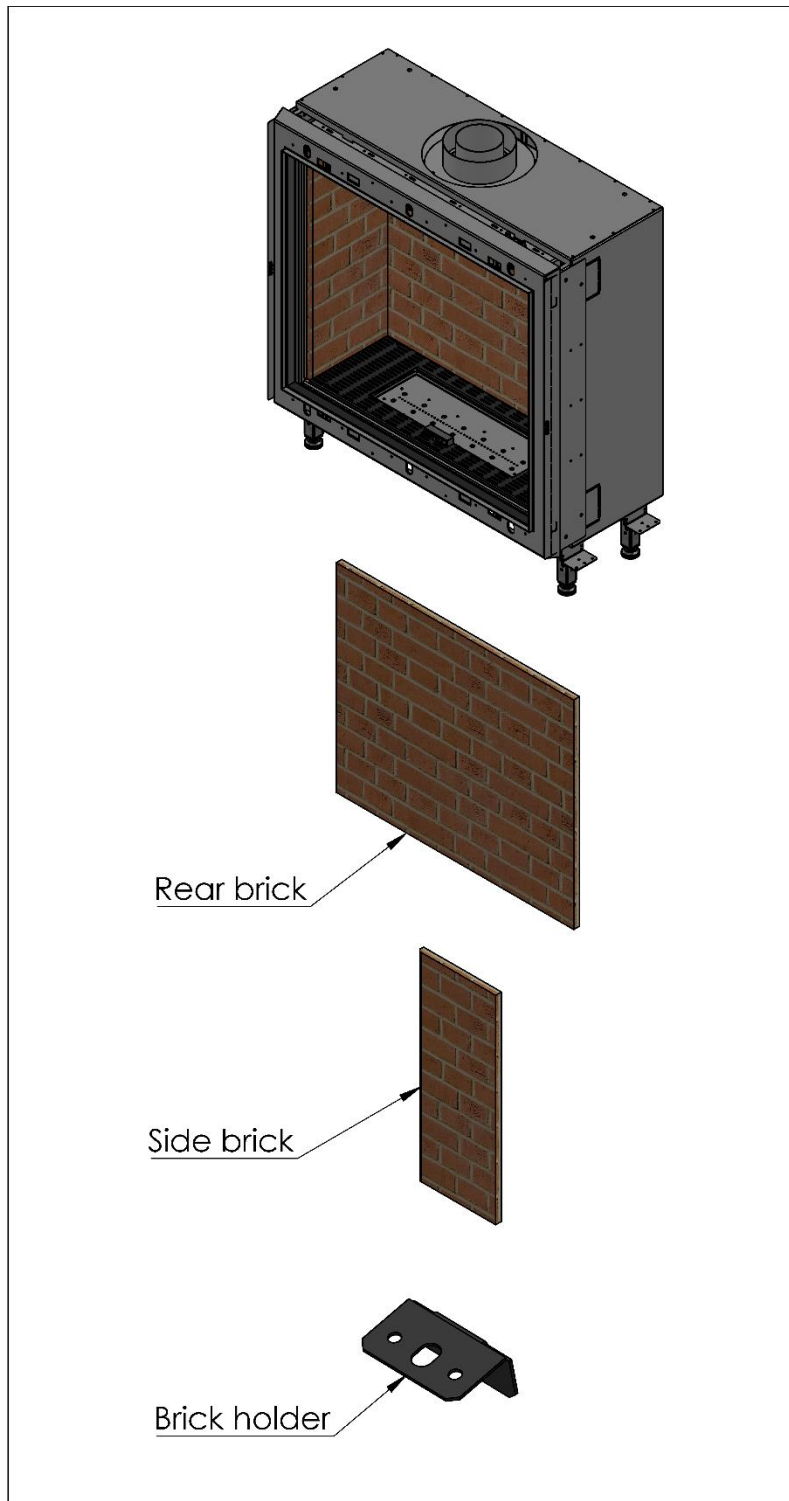

Figure 4: Components for Front Bricks Installation

To install front bricks:

1. Remove the heat barrier and the glass (Fireplace Heat Barrier on page 51).
2. Insert the rear brick.



NOTE: The side bricks hold the rear brick.



3. Insert the left and right side bricks.

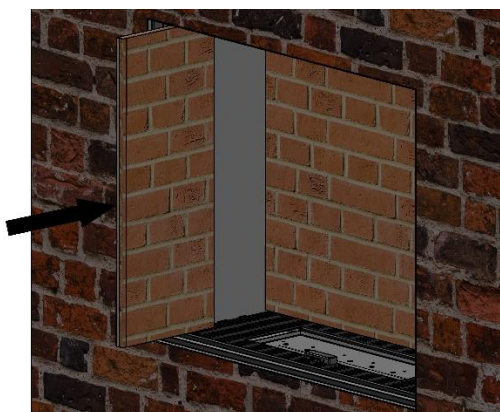

4. Insert the right and left brick holders, as shown.

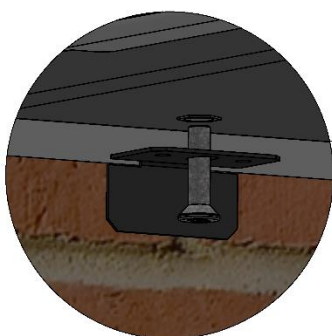

Traditional Bricks Installation

The following procedure provides guidelines for installing traditional bricks.

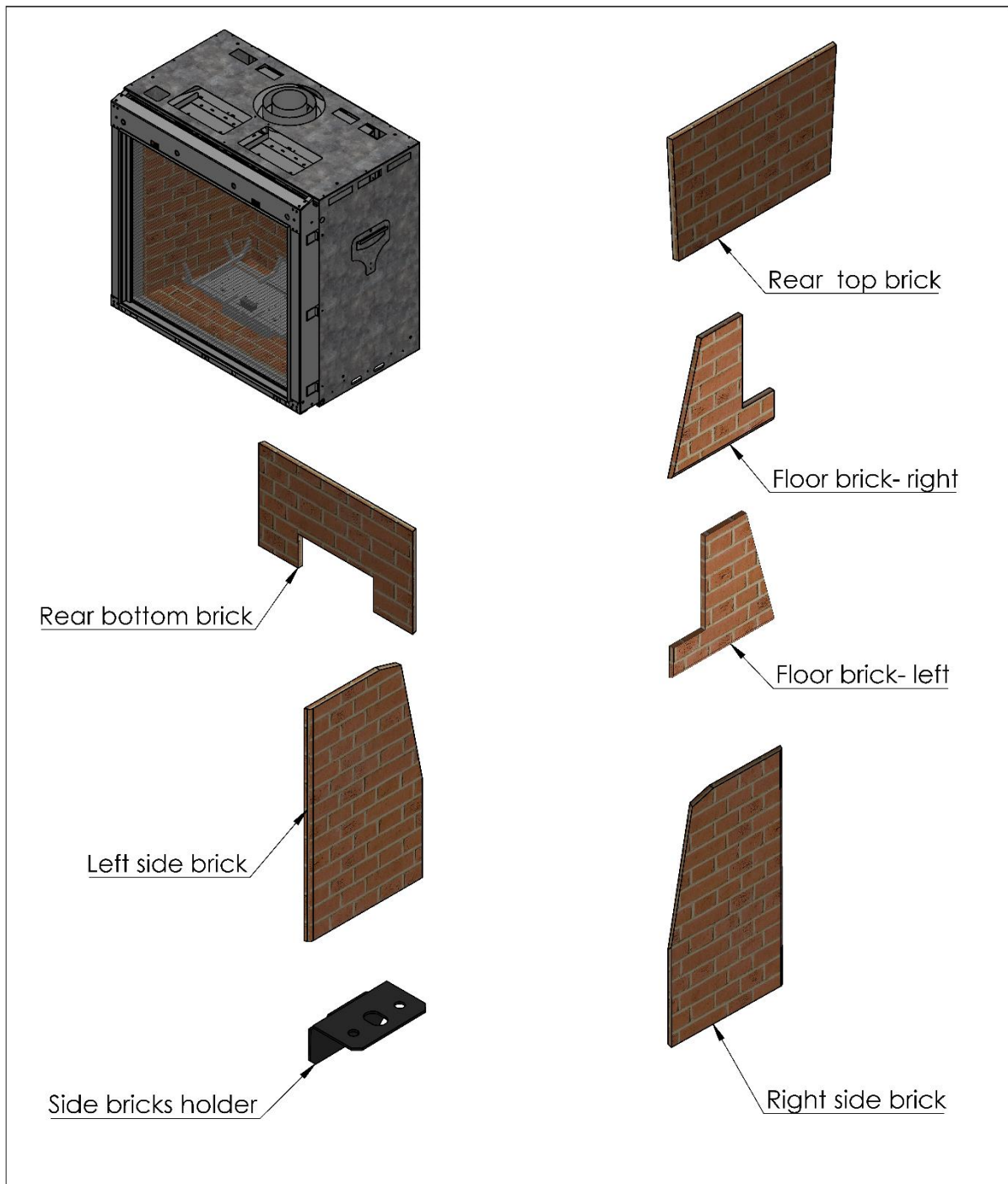
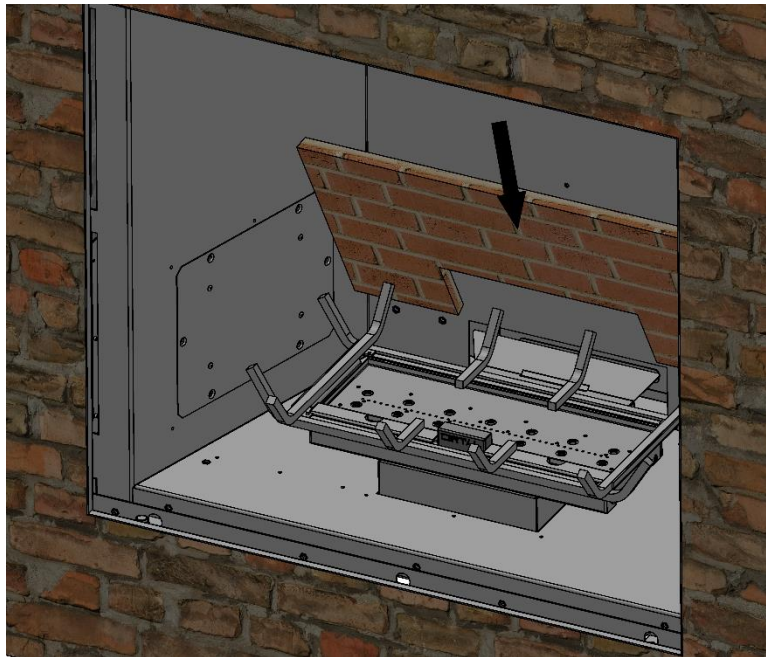

Figure 5: Components for Traditional Bricks Installation

To install traditional bricks:

1. Remove the heat barrier and the glass (Fireplace Heat Barrier on page 51).
2. Insert the rear lower brick.



3. Insert the rear upper brick.

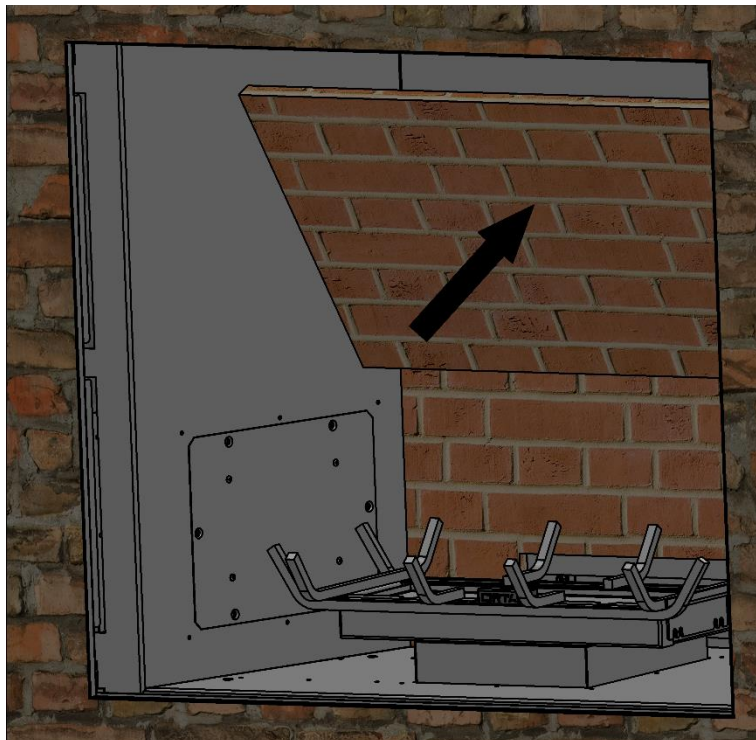

4. Insert the side bricks.

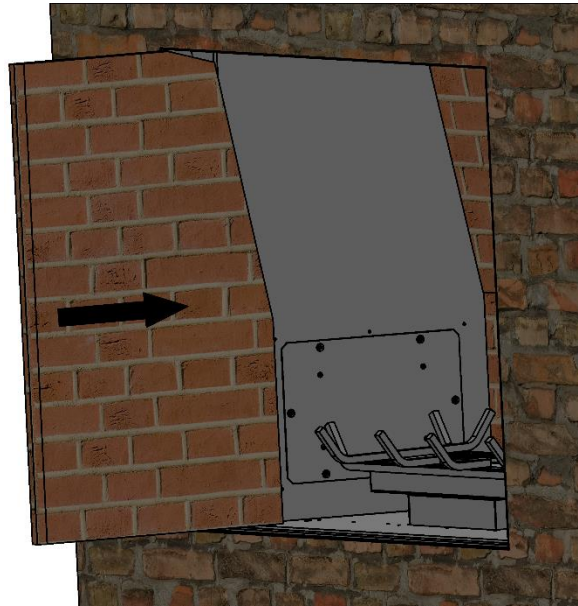

5. Insert the brick holders for each side, as shown.

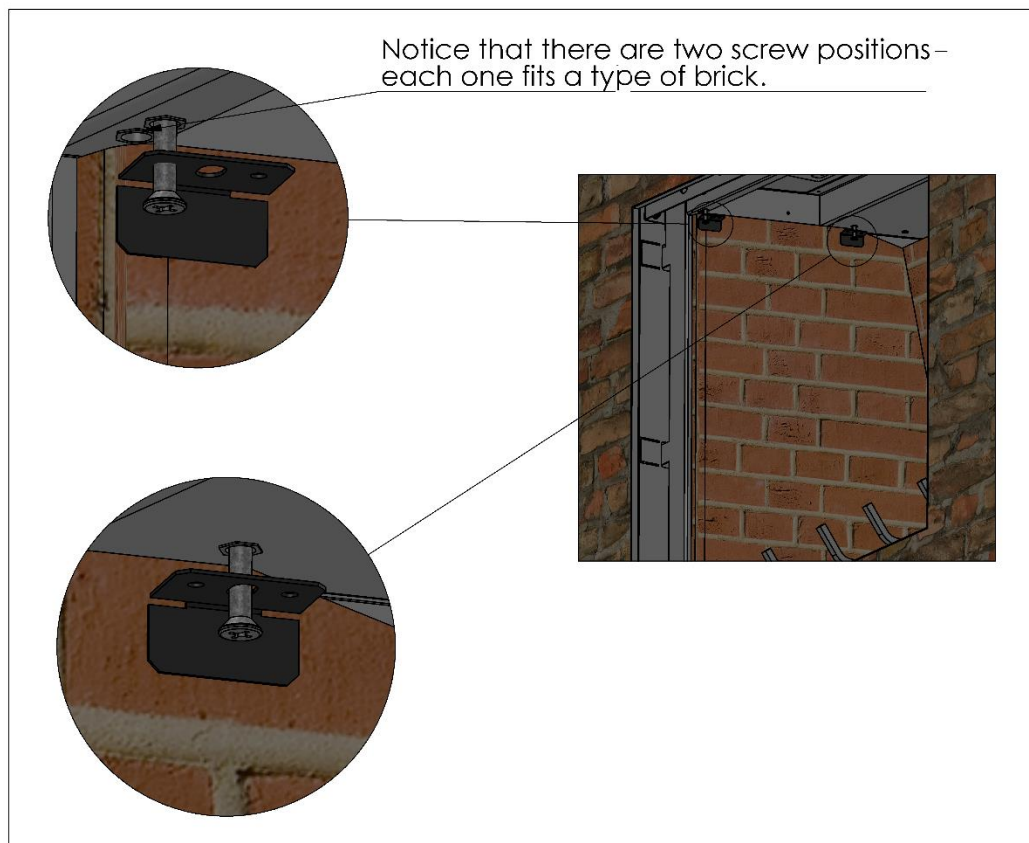

NOTE: The side bricks hold the rear bricks.

6. Push the right and left floor bricks into place, as shown.

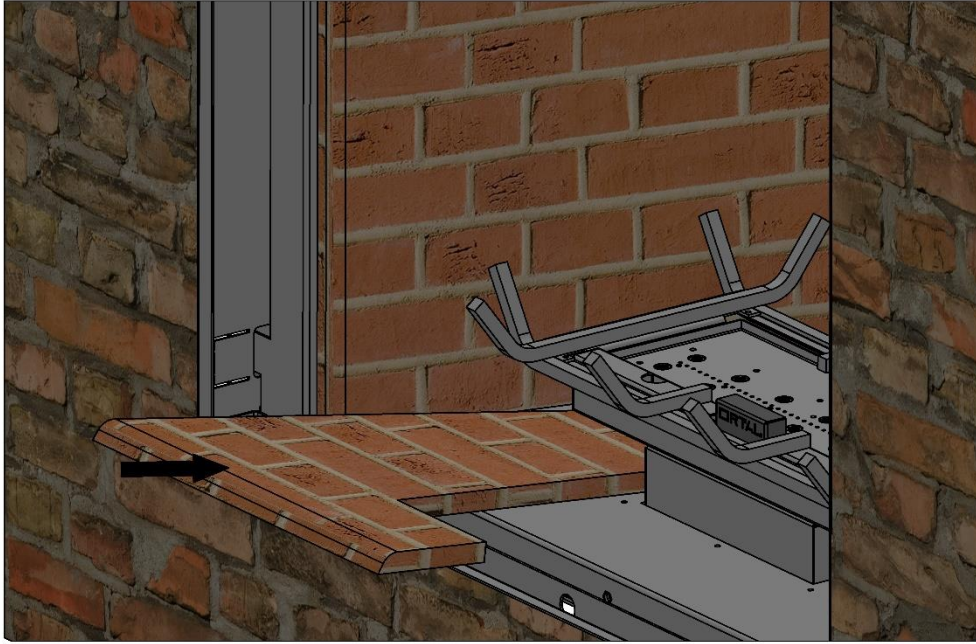

(a)

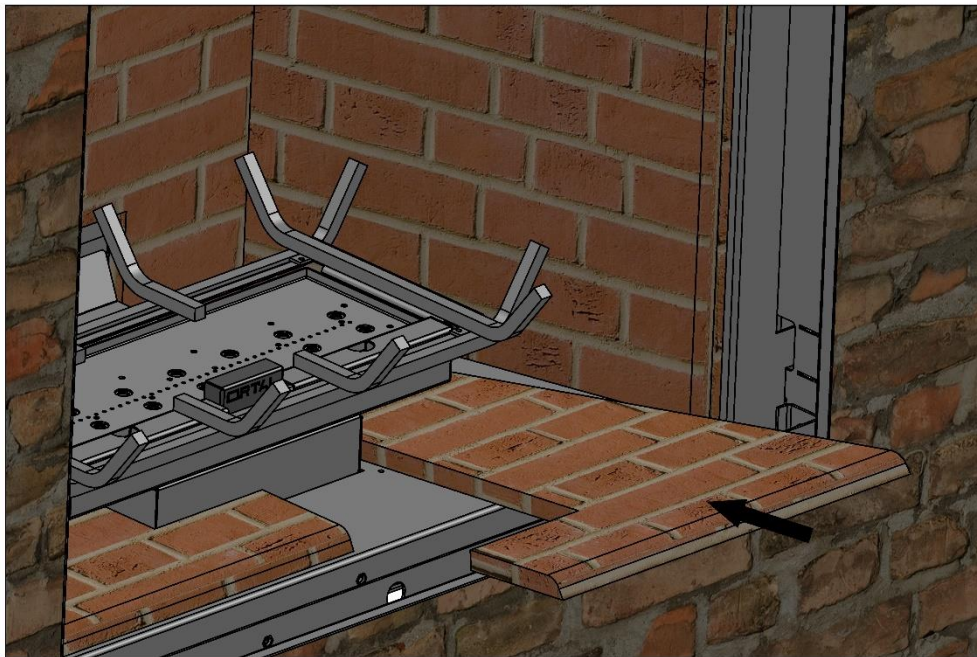

(b)

Electrical Requirements

⚠ WARNING: Disconnect the power supply before servicing any electrical components.

A duplex receptacle with two outlets (not included) must be installed in the location where the gas and electrical components will be placed, which must be to the side or back of the fireplace within **90 cm** of the pilot (see diagram in “Routing the Gas Line” section). Electrical work should be performed by a qualified licensed electrician, per local code.

Outlet Type	Power Requirements
1 Duplex Receptacle (2 outlets)	240V, 15 amp, 60Hz

⚠ WARNING: Use of an AC Adapter other than the one provided with the fireplace (manufactured by Mertik Maxitrol) may render the system inoperable.

ⓘ NOTE: Any device that functions using the same radio frequency as the handset will be affected when remote-controlled handset is in use.

Power Outage

Fireplaces with a screen heat barrier and no other optional features (lights, power flue, heat control system, Wi-Fi) may be used with 4 AA batteries in the receiver in addition to the AC Adapter. If the batteries are used instead of the AC Adapter, the fireplace can operate in the event of a power outage to the building. Batteries must be replaced annually.

Fireplaces with double glass heat barrier, power flue, or a heat control system may not be used with batteries.

Pairing the Remote and Receiver

To set up the remote-control device to operate the fireplace, follow the following guidelines to pair the remote and receiver unit on the same radio frequency.

1. Press and hold the receiver’s reset button until you hear two beeps. The first beep is short, and the second beep is long. After the second beep, release the reset button.



2. Within the subsequent 20 seconds, press the following button depending on the mode of operation:
 - **10-Button Handset:** Press the  button until you see the word “CONN” and a number counting up from 1 to 8 appear on the handset display. This confirms that the synchronization and data exchange are in process.
 - **Puck Handset:** Press and hold the – button approximately 4 seconds.
 - **Wall Switch:** Use the 10-button handset to synch with the receiver. Once the remote and receiver are paired, the wall switch will function normally.
3. You will hear two short beeps confirming the connection.

ⓘ NOTES:

- **IMPORTANT: For safety/communication purposes, 10-button handset must be located within 8 metres of the receiver.**
- If you hear one long beep, this indicates the connection has failed or the wiring is incorrect.
- The connection between remote and receiver only needs to be made once and is not required after changing the batteries in the remote.

Wiring Diagram

The following diagram shows the electrical wirings required.

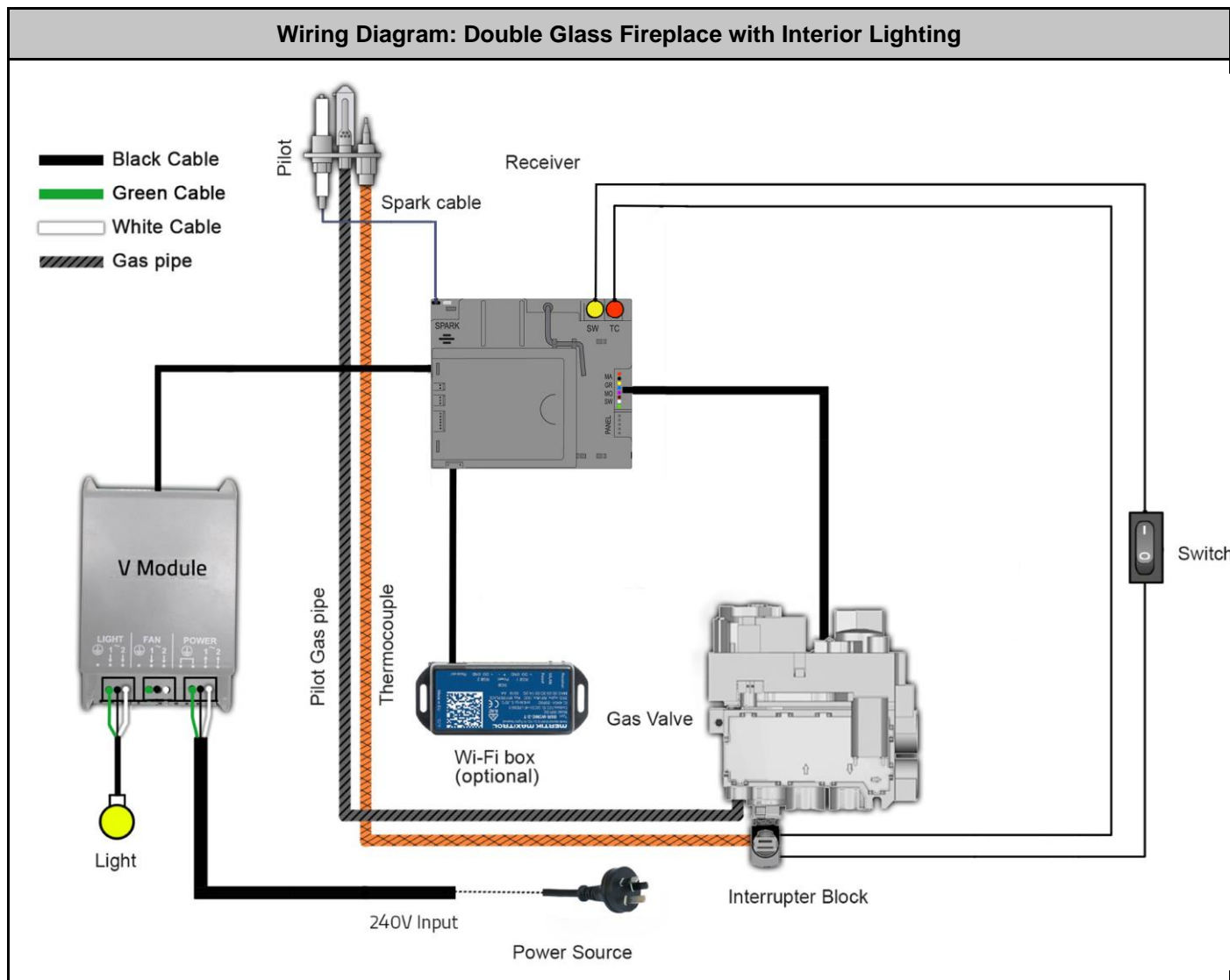

Home Automation Wiring Diagram

Use the following wiring diagram to connect fireplace control a hardwired home automation system.

Contacts Options/Operation

Ignition: Close contacts 0 (orange) and 2 (brown) simultaneously for 1 second. Fireplace automatically goes to high after ignition.

Up Flame: Close contacts 0 (orange) and 1 (red) simultaneously. The contact needs to be closed for 12 seconds to turn the motor from end-stop to end-stop.

Down Flame: Close contacts 0 (orange) and 3 (black) simultaneously. The contact needs to be closed for 12 seconds to turn the motor from end-stop to end-stop.

Off: Close contacts 0 (orange) and 3 (black) simultaneously for 1 second.

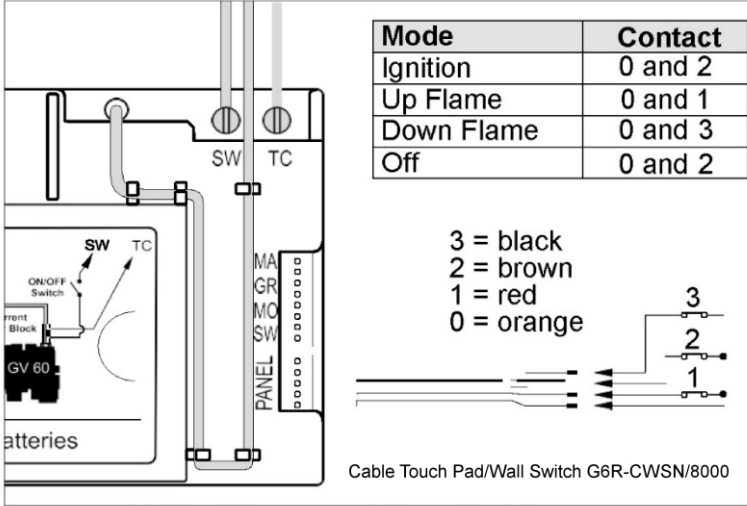

Mode	Contact
Ignition	0 and 2
Up Flame	0 and 1
Down Flame	0 and 3
Off	0 and 2

3 = black
2 = brown
1 = red
0 = orange

Wiring Diagram and Operation Sequence

Mode of Operation: The external source provides ON and OFF operation only. The Timer/Thermostat handset provides all other functions.

NOTICE: The Timer/Thermostat handset in Thermostatic Model controls the room temperature even if the fire is turned on by the external source. If the handset is in Manual Mode, the fire will go to High Fire in the next cycle of external operation.

NOTE: This wiring diagram is for hardwired home automation systems only and will not connect the fireplace to a wireless system.

Interior Design Media

ORTAL offers logs that are provided with the fireplace unit. This section provides guidelines for safe placement of media.



WARNINGS –INSTALLING AND HANDLING MEDIA

- DO NOT install the interior design media until appliance installation is complete, the gas line is connected and tested for leaks, and initial burner operation has been inspected and approved.
- ONLY install media provided by the manufacturer or otherwise specifically approved by the manufacturer for installation and operation with the unit.
- The size and position of the media was engineered to give the appliance a safe, reliable and attractive flame pattern. Any attempt to use different media in the fireplace will void the manufacturer's warranty and will result in incomplete combustion, sooting, and poor flame quality.
- Media materials get very hot and will remain hot up to one hour after gas supply is turned off. Handle media only when materials are cool.
- If media are not installed according to the installation instructions, flame impingement and improper combustion could occur and result in soot and/or excessive production of carbon monoxide (CO). Carbon monoxide is a colourless, odourless and toxic gas.
- **THIS APPLIANCE MAY EXHIBIT SLIGHT CARBON DEPOSITION**



The appliance is NOT designed to burn wood. Any attempt to do so could cause irreparable damage to the appliance and may result in property damage, personal injury and/or loss of life.

Media Placement Guidelines

When installing media, adhere to the following general guidelines:

- Keep the media back from the pilot so at least one burner port is open. Otherwise, there will be delayed ignition.
- Do not use the pilot to support media. This could cause overheating of the thermocouple.
- Keep the media away from the edges and the glass.
- Do not overfill the media tray. Keep 30% of the tray open to allow for airflow.
- When placing stone media, use the space left by the round shape to leave the ports open.
- Do NOT block ports. This will cause delayed ignition.

Media Setup

Wilderness Log Sets

Wilderness Logs are designed for use in the Wilderness series fireplaces only. No other interior design media options are permitted. The following Log sets are permitted for the Wilderness Series fireplaces:

Driftwood 70-3 Log Set

Valley Oak 70-3 Log Set

Birch 70-3 Log Set



NOTE: It can take up to 20 minutes for the flames to turn yellow.



WARNING: The fireplace is not designed to burn real wood. Any attempt to do so could cause irreparable damage to the fireplace and may result in property damage, personal injury and/or loss of life.

Log Installation Warnings

1. **Logs are fragile.** Handle them gently to prevent damage to their paint or to the fireplace.
2. **Arrange Logs as shown the section below.** Do not arrange them in any other way. If Logs are not installed per installation instructions, flame impingement and improper combustion may occur and result in soot and/or excessive production of carbon monoxide (CO). Carbon monoxide is a toxic, colorless, and odorless gas.
3. **Do not install the Log media until** fireplace installation is complete, the gas line is connected and tested for leaks, and initial burner operation has been inspected and approved.
4. **Keep 25 mm around the pilot (behind pilot hood) completely clear of any media or debris.** Contact between the metal strands and the spark plug cable may lead to failure operating the fireplace.
5. **Do not cover over the main burner holes** (marked in the image below) unless otherwise stated in this manual. Blocking the holes can cause a gas release that could cause an explosion in the fireplace.

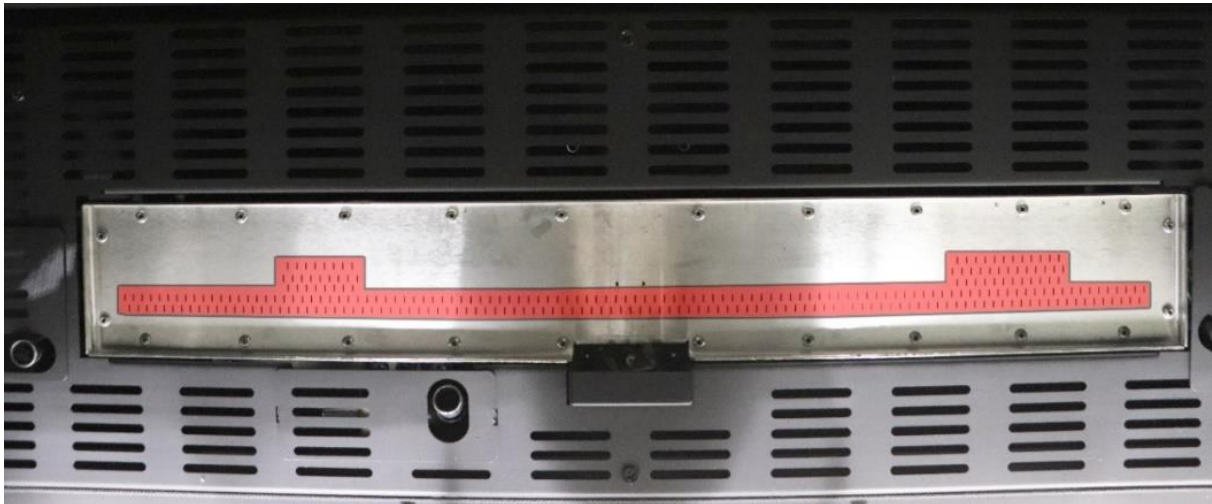

6. **Placing the log onto the log base/tube:**
Step 1: Grasp the log at both ends as shown in the picture



Step 2: Insert the tube coming out of the log into its base while making gentle rotational movements back and forth around its axis for easy insertion/removal. See figure below.

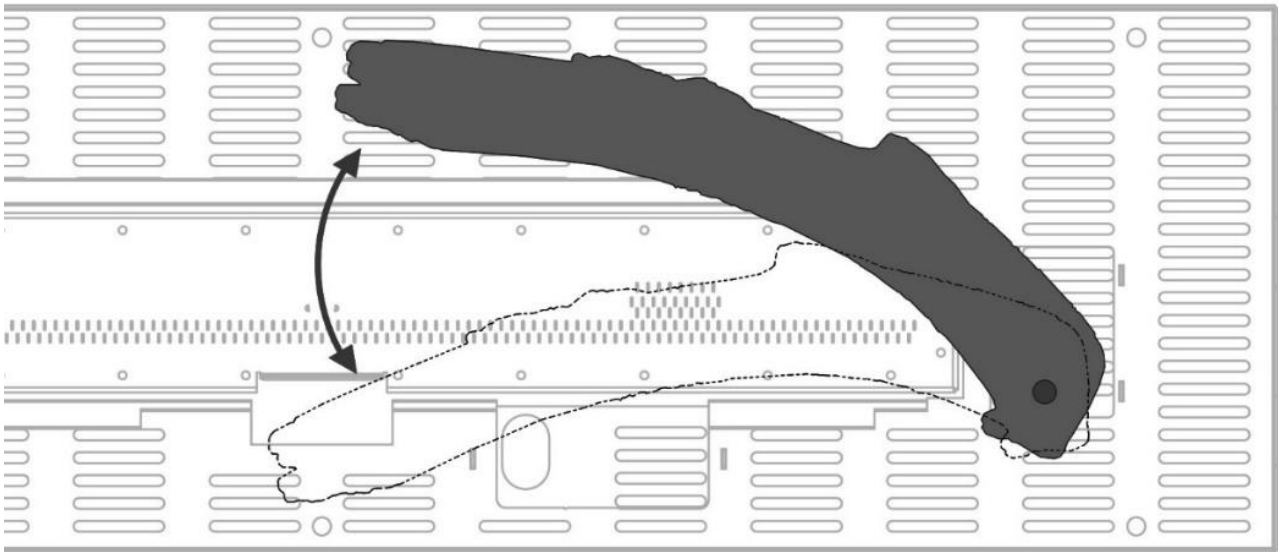

Top View

 **WARNING:** Using force when installing the log onto its base/gas tube may result in breakage or damage to the log that will require its replacement.

Log Arrangement for the following models

Wilderness 110 FR/RS/LS/TS

Wilderness Traditional 90 / 110

Driftwood Log set



Items supplied with Driftwood Log set

Log placement of the Driftwood Log Set is crucial for optimal fireplace operation and safety purposes. Logs must be arranged as detailed in the following pages. No other arrangement is permitted. Alternative log arrangement will affect fireplace safety, operation, and performance. Setup can take up to 1 hour to complete. Handle logs gently to avoid paint damage. Log placement is the same for NG and LP.

STEP 1: Metal Strands

1. Use your fingers to separate the metal strands (supplied 2x50 cm long) as shown in the image below. It is recommended to cut the metal strips into 10 equal strips to make it easier to separate them.



Left: Metal strands as supplied | Right: Metal strands ready to use

2. Place metal strands on top of the burner holes. Keep metal strands a minimum of 25 mm from the pilot.



⚠ WARNING: For safety and optimal fireplace function, keep 25 mm around the pilot (behind pilot hood) completely clear of any media or debris.

Arrange Logs as shown in Steps 2-9.

STEP 2

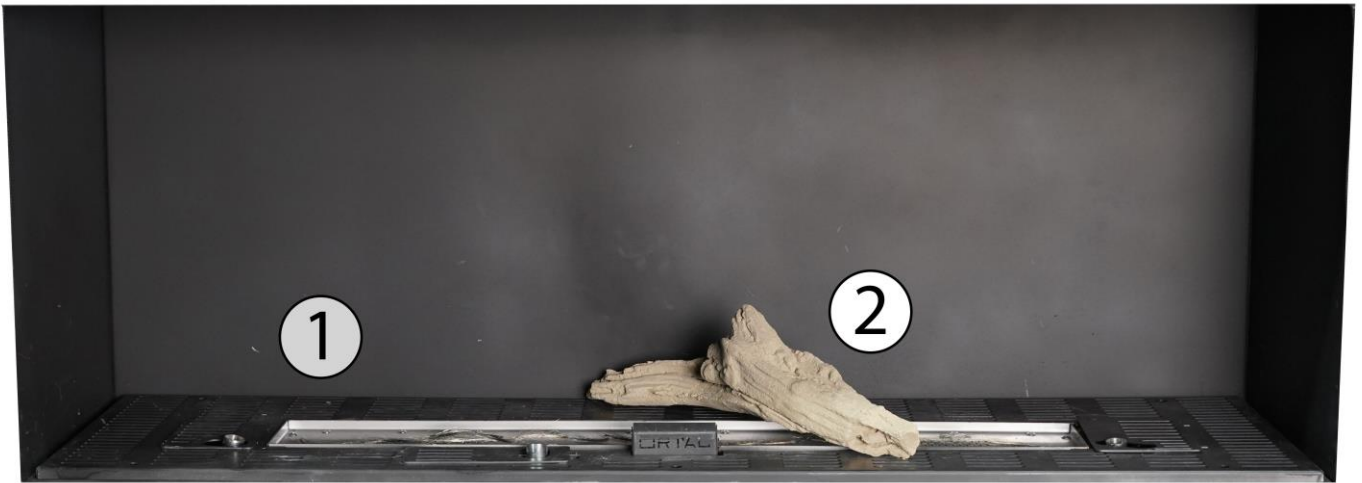

STEP 3



The base of log #3 can be adjusted to fit the position shown in pictures above,
(see "Error! Reference source not found." section on page 99 for details).

STEP 4



STEP 5



The base of log #5 can be adjusted to fit the position shown in pictures above,
(see “**Error! Reference source not found.**” section on page 99 for details).

STEP 6



STEP 7



The base of log #7 can be adjusted to fit the position shown in pictures above,
(see "Error! Reference source not found." section on page 99 for details)

STEP 8



STEP 9

Add charcoal pieces to the bottom of the firebox. Do not cover any burner holes. Maintain minimum 25 mm clearance around the pilot (behind pilot hood).



⚠ WARNING: For safety and optimal fireplace function, keep 25 mm around the pilot (behind pilot hood) completely clear of any media or debris.

Log Arrangement for the following models

Wilderness 130-150-170 FR/RS/LS/TS

Driftwood Log set



Items supplied with Driftwood Log set

Log placement of the Driftwood Log Set is crucial for optimal fireplace operation and safety purposes. Logs must be arranged as detailed in the following pages. No other arrangement is permitted. Alternative log arrangement will affect fireplace safety, operation, and performance. Setup can take up to 1 hour to complete. Handle logs gently to avoid paint damage. Log placement is the same for NG and LP.

STEP 1: Metal Strands

1. Use your fingers to separate the metal strands (supplied 2x50 cm long) as shown in the image below. It is recommended to cut the metal strips into 10 equal strips to make it easier to separate them.



Left: Metal strands as supplied | Right: Metal strands ready to use

2. Place metal strands on top of the burner holes. Keep metal strands a minimum of 25 mm from the pilot.

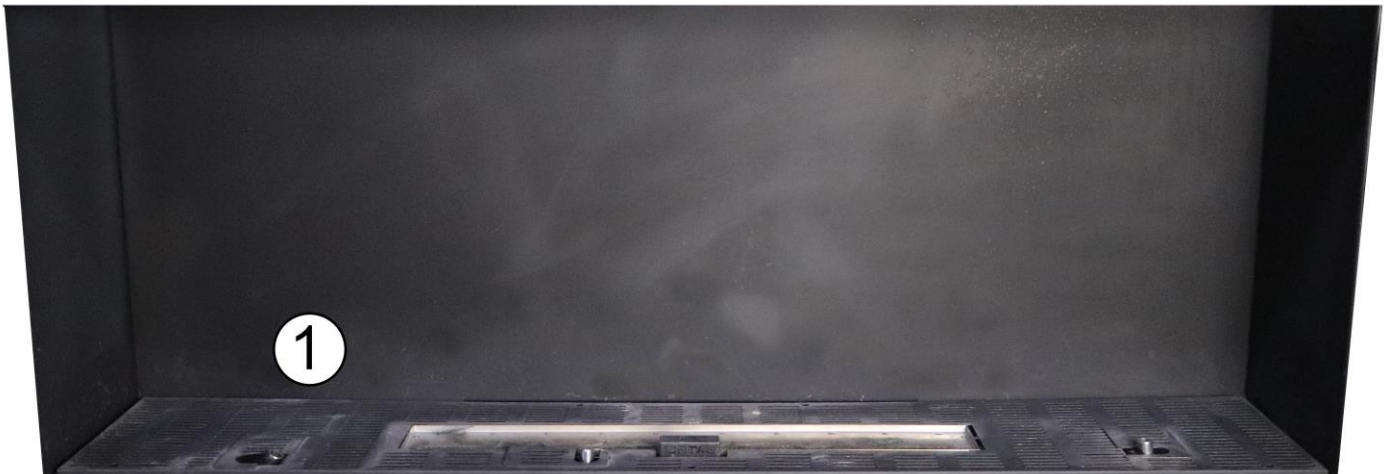

⚠ WARNING: For safety and optimal fireplace function, keep 25 mm around the pilot (behind pilot hood) completely clear of any media or debris.

Arrange Logs as shown in Steps 2-9.

STEP 2

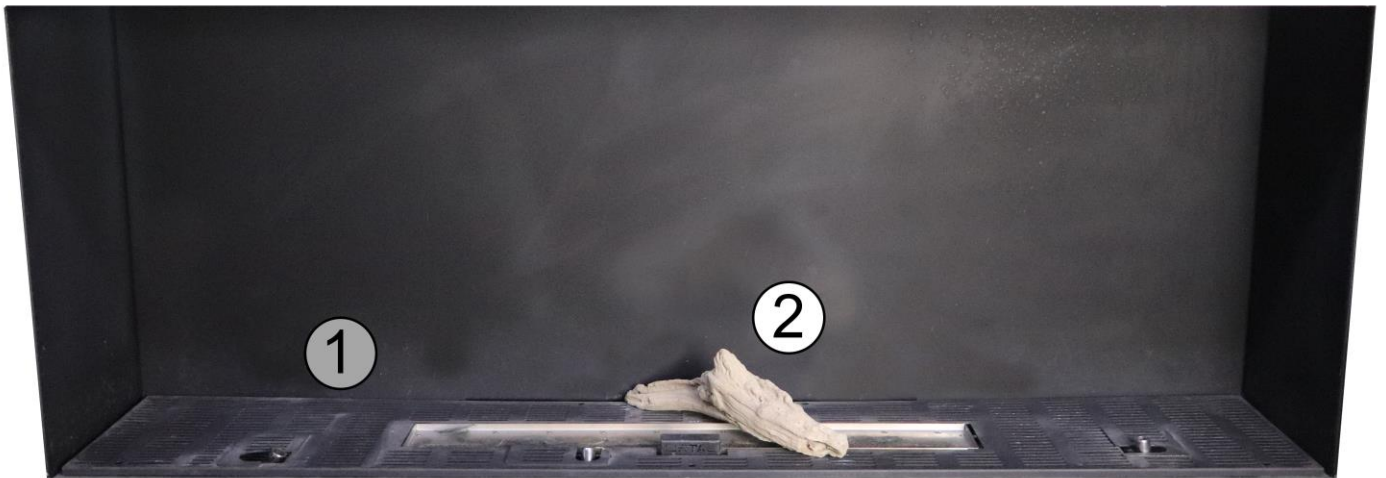

STEP 3

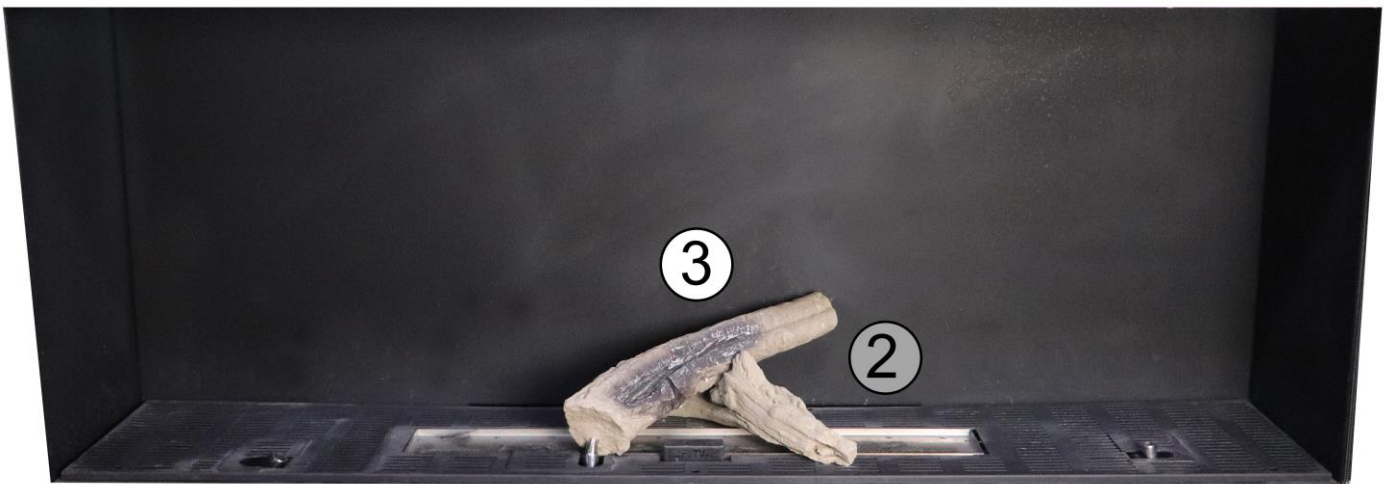

The base of log #3 can be adjusted to fit the position shown in pictures above,
(see "Error! Reference source not found." section on page 99 for details).

STEP 4

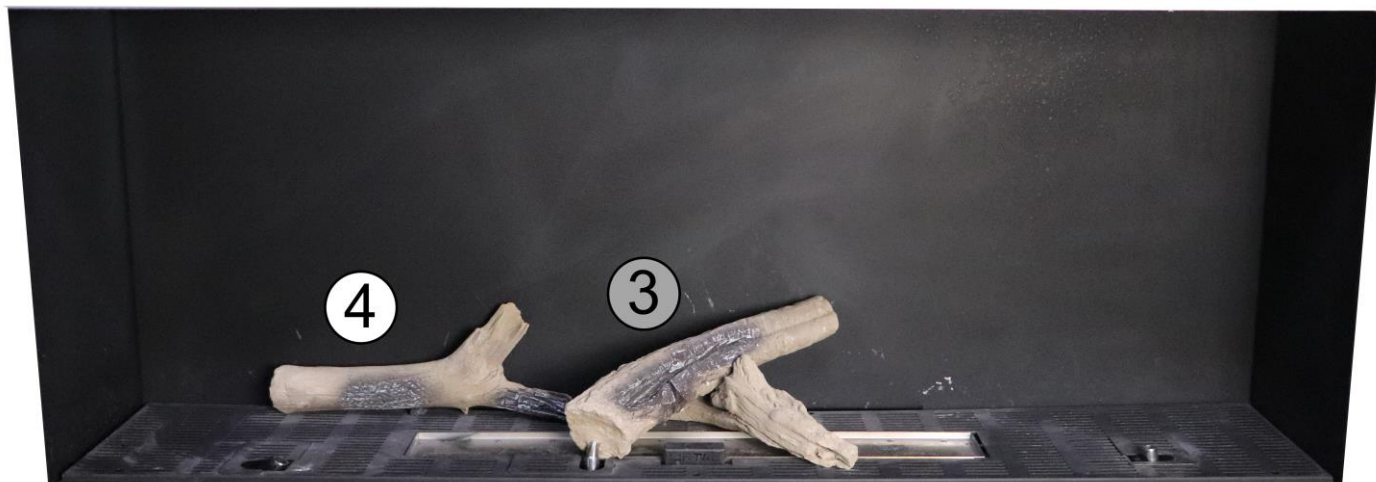

STEP 5

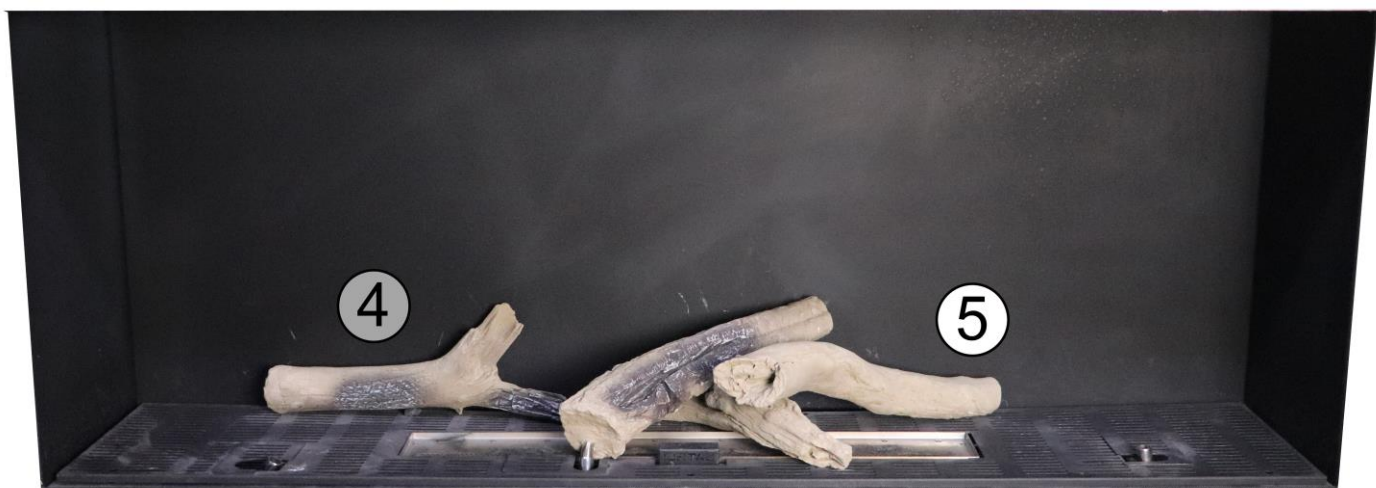

STEP 6



The base of log #6 can be adjusted to fit the position shown in pictures above, (see "Error! Reference source not found." section on page 99 for details).

STEP 7



The base of log #7 can be adjusted to fit the position shown in pictures above, (see “**Error! Reference source not found.**” section on page 99 for details)

STEP 8



STEP 9

Add charcoal pieces to the bottom of the firebox. Do not cover any burner holes. Maintain minimum 25 mm clearance around the pilot behind pilot hood.



 **WARNING:** For safety and optimal fireplace function, keep 25 mm around the pilot (behind pilot hood) completely clear of any media or debris.

Operation



WARNING – Read these instructions carefully before lighting the fireplace.

Four operation options are available for use with the fireplace:

- 10-Button Remote Control Handset (default option, always included with the fireplace)
- Puck Handset (optional accessory)
- Wall Switch (optional accessory)



IMPORTANT: The 10-Button remote control handset is always included with the fireplace regardless of which operation option is chosen. **DO NOT DISCARD. The 10-Button remote must be kept within 8 metres of the fireplace at all times.**



NOTES:

- Wiring of valve and receiver must be completed before starting ignition. Failure to do so could damage the electronics.
- If operating the fireplace without an AC adapter, battery replacement is recommended at the beginning of each heating season.
- Fireplaces with double glass, power flue, and/or interior lighting features must operate using the AC Adapter and therefore will not operate during a power failure.
- Only the Mertik Maxitrol AC Adapter is permitted for use with the fireplace. Use of other adapter brands can render the system inoperable. The handsets, receivers, wall switches are not interchangeable with other electronics.
- Batteries must be kept within their recommended temperature limits (0°C to 55°C).

10-Button Remote Control Handset

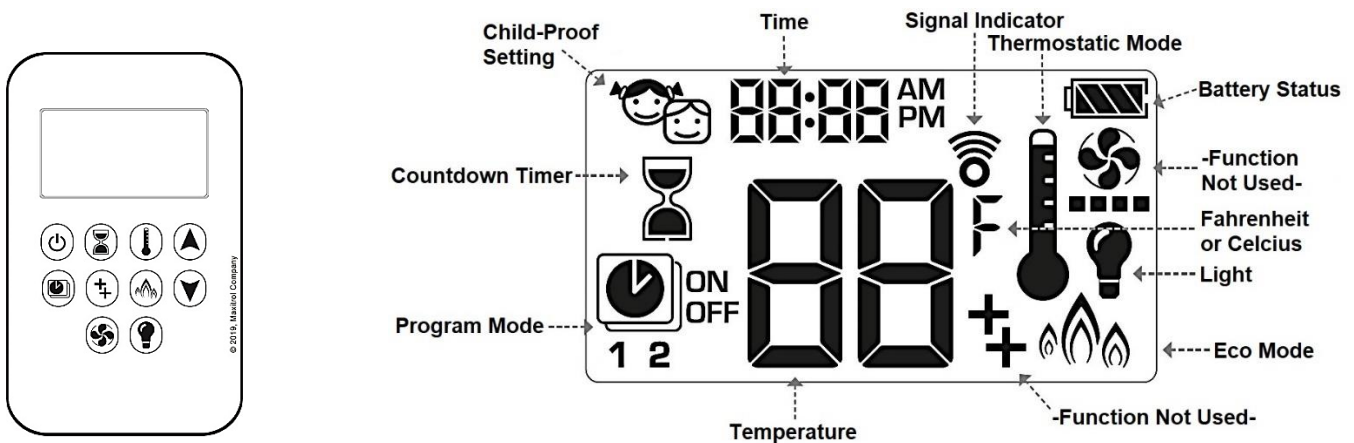

© 2019, Maxitrol Company

Control Option	Radio Frequency	Power Supply	
10-Button Handset	918.0 MHz	2 x 1.5V AAA batteries (quality alkaline recommended)	Replace batteries after 2 years or when low battery indicator appears on handset display
IMPORTANT: For safety/communication purposes, 10-button handset must be located within 8 metres of the receiver.			

NOTE: Any device that functions using the same radio frequency as the handset will be affected when handset is in use.

Operating Instructions

Instructions for operating the 10-Button Handset are shown below. For more in-depth instructions, please refer to the “Homeowner’s Fireplace Operation Manual” or “Remote Operation Instructions”.

NOTE: Some options on the remote may not be available for all fireplaces.

Turning the Fireplace On



1. Press the  button until you hear continuous beeping, and a blinking series of lines confirms the start sequence has begun; release buttons.
2. Main gas flows once pilot ignition is confirmed.
3. The system automatically goes into Manual Mode after main burner ignition.

 **NOTE:** When pilot ignition is confirmed, motor turns automatically to maximum flame height.

 **NOTE:** If the Timer function has been set and the fireplace is manually turned on, the Timer function will need to be reset.

Turning the Fireplace Off



1. Press the  button to turn the fireplace off.

 **NOTE:** The fireplace may be turned on again after the OFF icon stops flashing.

Flame Height Adjustment

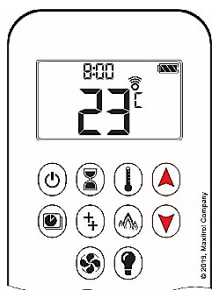

1. To increase flame height, press and hold the  button to desired flame height.
2. To decrease flame height, or to set fireplace to pilot flame only, press and hold the  button.

Wall Switch

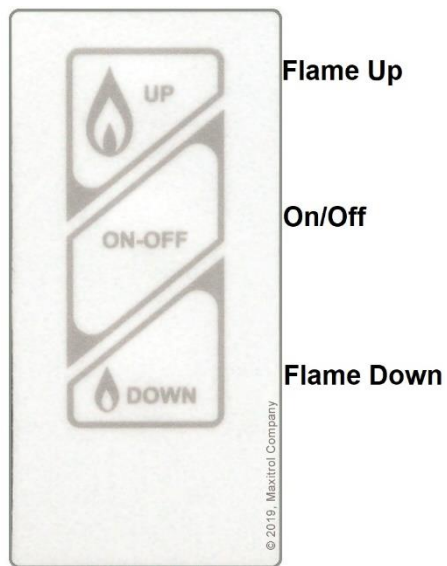

Control Option	Radio Frequency	Power Supply
Wall Switch	N/A	N/A
IMPORTANT: For safety/communication purposes, the 10-button handset must be located within 8 metres of the receiver.		

Operating Instructions

Turning the Fireplace On/Off

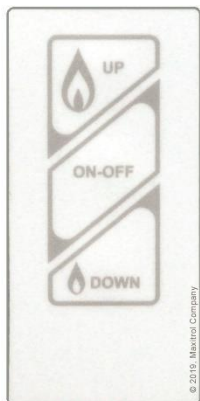

On/Off

ON: Press and hold the **ON-OFF** button until two short beeps confirms the start sequence has begun; release button.

OFF: Press the **ON-OFF** button.

Flame Height Adjustment



Flame Up

INCREASE: To increase flame height, press and hold  (up flame) button.

DECREASE: To decrease flame height, press and hold  (down flame) button.

Holding the  (down flame) button long enough sets the fireplace to pilot flame (Standby Mode).

Flame Down

General Maintenance

All servicing, maintenance, interior cleaning and handling of the fireplace, parts and glass must be performed by an authorized Ortal dealer service technician only.

Servicing

- Turn off the gas and electricity **BEFORE** servicing the fireplace.
- It is recommended that a routine inspection is performed at the beginning of each heating season.
- When removing glass from multisided fireplaces, only one side of glass can be removed at a time. Glass must be re-installed before removing glass from a different side.

Burner and Flue Inspections

- Periodic checks should be made of the burner for correct position and condition. Visually check the flame of the burner, making sure that the flames are steady.
- The flue system must be inspected before use. Annual inspection must be scheduled to ensure the flow of combustion and ventilation air.

Submerged Parts

- Do not use the fireplace if any part has been under water, or if you suspect that it may have been under water. The Ortal dealer service technician must inspect and, if necessary, replace any parts of the control system and any gas controls which have been under water.

Handling the Glass

Inner glass panel is 5mm ceramic glass. Exterior double glass panel is 5 mm tempered glass. Tempered glass can be sourced locally if replacement becomes necessary. Ceramic glass must be provided by Ortal.

- When removing glass from multisided fireplaces, only one side of glass can be removed at a time. Glass must be re-installed before removing glass from a different side.
- **NEVER** operate the fireplace without the glass properly secured in place.
- The glass must be removed **ONLY** by an authorized Ortal dealer service technician.
- Only an Ortal certified installer is authorized to remove the glass. Glass must be removed using a 20 cm glass-handling suction cup. Lower the glass to rest in a safe place to prevent damage to the glass edges.

Cleaning the Fireplace

- Only an Ortal dealer service technician can open the fireplace to clean interior surfaces.
- **ALWAYS** turn off the gas valve before cleaning.
- Do **NOT** clean when hot. Make sure fireplace has had time to cool prior to cleaning any surface or component, interior or exterior.
- Keep the fireplace clean by brushing and/or vacuuming at least once a year. This can only be performed by an Ortal dealer service technician.
- When removing glass from multisided fireplaces, only one side of glass can be removed at a time. Glass must be re-installed before removing glass from a different side.
- Clean the glass when it starts to look cloudy. Use a damp cloth for cleaning the fireplace and the door.
- Verify correct operation after servicing.

Maintenance Frequency and Equipment Checklist

- Under normal circumstances, the factory recommendation is to have the fireplace serviced at least once a year. Fireplaces meeting the following conditions should have more frequent service:
 - Fireplaces installed in commercial/public spaces should be serviced every 3 months.
 - Fireplaces installed in climates near the ocean or in other settings where corrosion build-up is more likely should be serviced every 6 months.
- Thermocouple Maintenance:
 - The thermocouple should be replaced annually or as needed in all commercial installations, and in any residential fireplace where the fireplace is operated for an average of 10 hours or more per day.
 - For all other installations, the thermocouple should be replaced every three years or as needed.

Appendix A: Fireplace Troubleshooting Guide

This appendix provides information and guidelines for troubleshooting, including:

- Pre-troubleshooting Checklist on page 113
 - Normal Sequence of Fireplace Operation on page 115
 - Troubleshooting Pilot Problems on page 117
 - Troubleshooting Thermocouple Problems on page 119
 - Troubleshooting Main Burner Problems on page 120
 - Troubleshooting Beeping on page 122
 - Mertik Maxitrol External Source Operation on page 124
-

Pre-troubleshooting Checklist

Before you begin troubleshooting, perform these steps:

1. Check the batteries and 6V transformer connection.
2. Verify that the switch on the valve is ON.
3. Verify that the MANUAL/ON knob on the valve is in the ON position (Figure 6 on page 96).



Figure 6: ON/OFF and Manual Pilot Valve Switches

4. Verify that the gas is ON.
5. Using the purge port, purge the gas line of air up to the valve (see figure below).

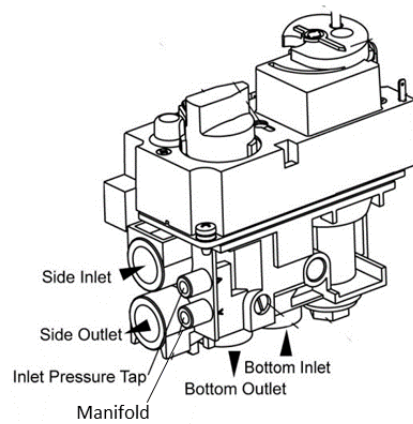

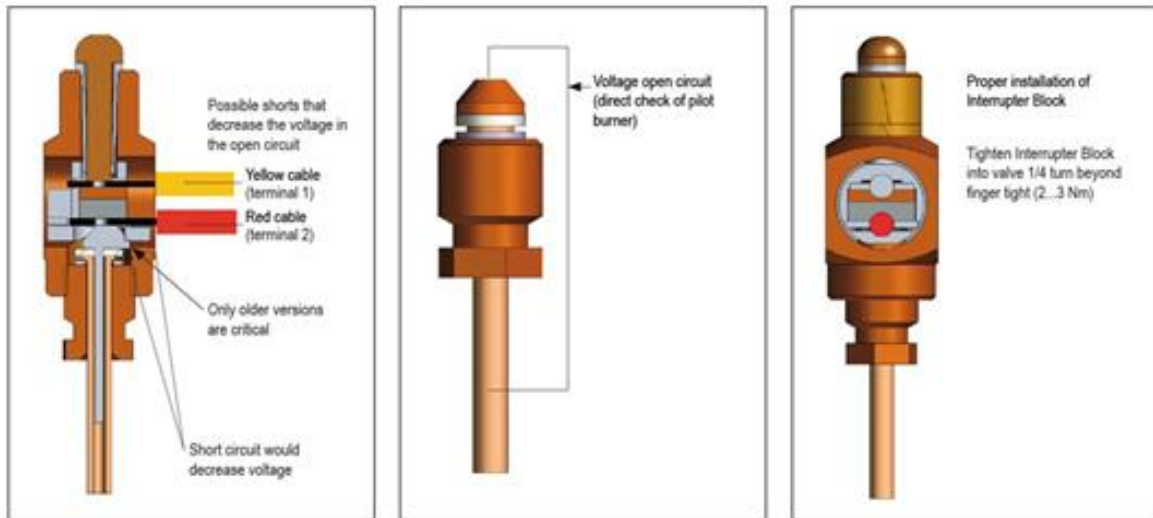

6. Using the purge port, check the pressure of inlet/ supply (see figure above).
Inlet pressure for NG should be 7 WC

7. Verify that the valve and receiver wires are properly connected and tight, and that the interrupter block is tight (hand-tight plus ¼ turn).

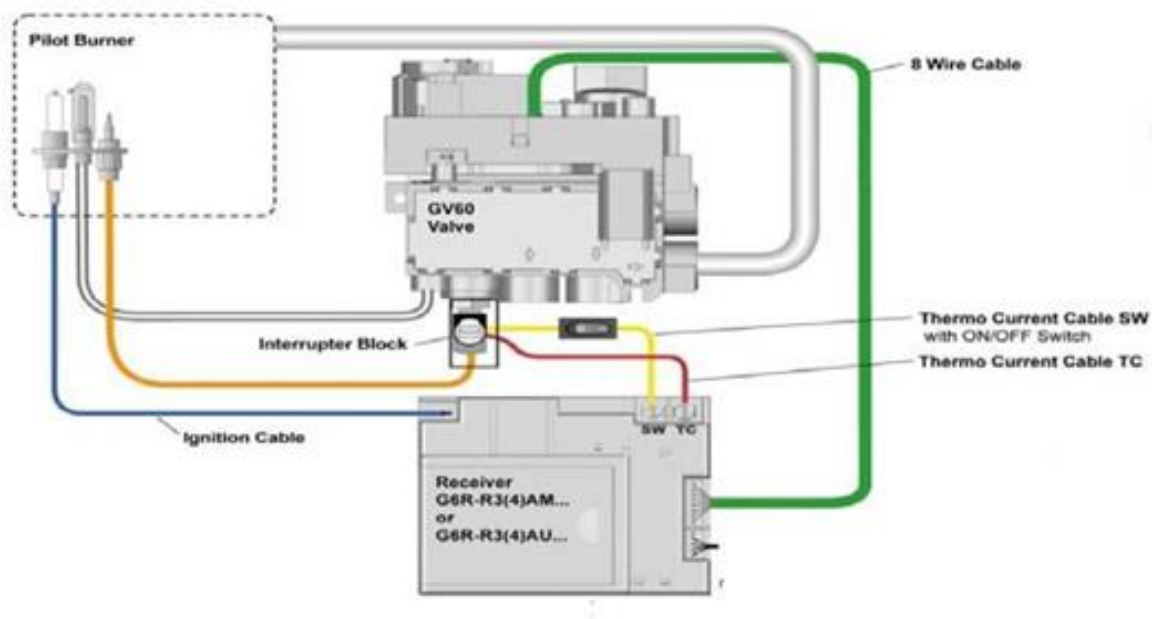

Figure 7: Valve/Receiver Wires and Interrupter Block

Normal Sequence of Fireplace Operation

Turn the fireplace on by pressing the Off/On button.



Figure 8: ORTAL Remote Control

Once the fireplace is turned on, the following sequence of events will occur:

1. The system checks itself for any trouble. This is accompanied by sequential beeps. See the following beeping and fault code table.

CONFIRMATION IGNITION START	
FAILURE:	
Micro switch defect	
ON-OFF Switch open	
WIRING NOT COMPLETED	
LEARN FUNCTION FAILED	
2 nd THERMOCOUPLE CONNECTED TO STANDARD VERSIONS (WHITE STICKER ON THE RECEIVER'S BACKSIDE)	
NO 2 nd THERMOCOUPLE CONNECTED TO 2 nd THERMOCOUPLE VERSION (YELLOW STICKER ON THE RECEIVER'S BACKSIDE)	
IGNITION TRIED WHILE 2 nd THERMOCOUPLE HAS NOT COOLED DOWN YET	
LOW BATTERY (During the motor turns)	
RESET also Batteries changed, Power on	
LEARNING FUNCTION	<p style="text-align: center;">PUSH RESET PUSH SMALL FLAME</p> <p style="text-align: center;">CONFIRMS CODE LEARNING</p>

2. If the initial check is okay, the system initiates spark to the pilot and opens gas to the pilot only.
3. Once the pilot is on, the pilot heats up the thermocouple.

4. When the thermocouple is heated to the required temperature, it will allow the flow of the millivolt to the valve.
5. Once the millivolt is detected by the valve, the valve turns the solenoid for the main burner ON. The fireplace is now fully on.

Troubleshooting Pilot Problems

The following sections provide step-by-step instructions for troubleshooting issues related to the pilot. If these instructions fail to resolve the problem, please contact ORTAL.



Before beginning, make sure that the glass protective film has been removed.

Spark But No Pilot

1. Review the Pre-troubleshooting Checklist on page 96.
2. Review the Normal Sequence of Fireplace Operation on page 98.
3. Make sure the inlet line is purged and that no air is present.
4. Make sure that the valve is mounted horizontally (unless it is a hanging Console Appliance unit).
5. To purge the pilot tube of any air, turn the unit on 5-10 times.
6. Verify that all wire connections are tight. Then, check that the interrupter block is screwed in tightly but not too tightly (tightening the interrupter block too much will break it). Refer to Figure 7 on page 97 for details.
7. If the problem is not resolved, call ORTAL.

No Spark to the Pilot

1. Review the Pre-troubleshooting Checklist on page 96.
2. Review the Normal Sequence of Fireplace Operation on page 98.
3. Locate the valve and receiver.
 - a) Once the receiver is located, pull it from the holder.
 - b) Disconnect the wire for the spark wire. Refer to Figure 7 on page 97 for details.
 - c) Put a small wire on the receiver spark wire port, and place the other side of the wire close to the metal body without touching (about 3mm) While watching the small wire, turn the unit on and see if there is a spark jumping from the wire to the body of the fireplace. If there is, proceed to the next step. If there is not, call ORTAL.
4. Remove the heat barrier and the glass. For instructions, refer to Fireplace Heat Barrier on page 51.
5. Remove the grill and the burner. For instructions, refer to **Error! Reference source not found.** on page **Error! Bookmark not defined.**
6. Remove the pilot assembly from the burner.
7. Reconnect the spark wire and disconnect the wire from the spark plug. Place the spark wire close to the metal body of the fireplace without touching (about 3mm). If there is no spark or a weak spark jumping from the wire, replace the wire. If the spark is strong and jumping, proceed to the next step.
8. If the problem is not resolved, replace the spark plug. Call ORTAL if a spark plug is needed.

Pilot Turns Off After Igniting But Before Burner Turns On

1. Replace the battery.

2. Review the Normal Sequence of Fireplace Operation on page 98.
3. Turn the unit on, and listen and look at the pilot section. Once the pilot is on, is the spark continuing to ignite the pilot? If it is, go to Troubleshooting Thermocouple Problems on page 102. If it is not, proceed to the next step.
4. Remove the heat barrier and the glass. For instructions, refer to Fireplace Heat Barrier on page 51.
5. Make sure the pilot assembly and the pilot hood screw are tight and that there is a gasket. Whenever the pilot assembly is disturbed, replace the gasket.
6. If the problem is not resolved, call ORTAL.

Pilot Turns Off After Igniting and After Burner Turns On

1. Review the Normal Sequence of Fireplace Operation on page 98.
2. Remove the heat barrier and the glass. For instructions, refer to Fireplace Heat Barrier on page 51.
3. Make sure that the valve is mounted horizontally (unless it is a hanging Console Appliance unit).
4. Turn the unit on and see if the pilot is still turning off after the burner turns on. If it turns off, make sure the flame from the pilot is hitting the thermocouple.
5. Verify that the pilot assembly and pilot hood screw are tight, and that the pilot assembly gasket is present and in good condition.
6. Review the restrictor tables and check that the correct restrictor is in place.
7. If the problem is not resolved, call ORTAL.

Troubleshooting Thermocouple Problems

The following sections explain how to check and test the thermocouple.

Checking the Thermocouple

Perform these steps to check the thermocouple. Refer to Figure 7 on page 97 for details.

1. Place new batteries in the receiver.
2. Check for any breakage to the thermocouple from pilot assembly to the valve.
3. Check that the thermocouple is tightly connected to the interrupter block and that the thermo current cable is securely touching the end of the thermocouple.
4. Verify that the interrupter block is screwed into the valve properly and is finger-tight, plus ¼ turn.
5. Verify that the thermo current cable TC is screwed into the receiver properly and is tight.
6. Verify that the thermo current cable SW is screwed into the receiver properly and is tight.
7. Verify that the thermo current cable SW is securely placed in the interrupter block.

Testing the Thermocouple

Perform these steps to test the thermocouple. Do not begin testing until the thermocouple check has been completed.

1. Remove the heat barrier and the glass. For instructions, refer to Fireplace Heat Barrier on page 51.
2. Turn off gas to the unit.
3. Turn the unit on. While the spark is sparking, place a heat source to the thermocouple. Sparking should stop once the thermocouple senses that there is heat. If the spark does not stop, go to Step 5.
4. Check that the thermocouple is screwed properly into the interrupter block. Verify that the thermo current cable is screwed in tightly at the receiver, and that the other end is touching the head of the thermocouple at the interrupter block.
5. If the problem is not resolved, the thermocouple should be replaced. Complete a part claim/replacement form and call ORTAL for replacement.

Troubleshooting Main Burner Problems

The tables below provide instructions for troubleshooting issues related to the main burner and the flame.







Problem	Possible Causes	Recommended Actions
Main burner does not turn on. Pilot is on, and valve on sequence is done.	Manual pilot valve operation is off.	Verify that the manual pilot valve operation is in the ON position.
Main burner turns off after a period of time.	<ul style="list-style-type: none"> • Thermostat is set too low. • There is a problem with the flame. 	<p>Check whether the pilot stays on when the main burner turns off.</p> <ul style="list-style-type: none"> • If the pilot stays on, make sure the remote thermostat is set to the desired temperature or to the highest temperature allowed on the remote, so the system does not turn the burner off. • If the pilot does not stay on, check the appearance of the flame before the fireplace turns off. Refer to Troubleshooting Flame Issues on page 104.
Main burner is turning on and off.	The pilot flame is being intermittently deflected off the thermocouple.	Make sure the pilot assembly screw is tight and that the gasket is present and in good condition.

Troubleshooting Flame Issues

Problem	Possible Causes	Recommended Actions
There is a faint or blue flame.	<ul style="list-style-type: none"> • Too much CO in the fireplace, due to CO back feeding or an unapproved flue run. • Too much O2 in the fireplace. 	<ul style="list-style-type: none"> • Review the flue run. If the size of the restrictor in the unit is incorrect, replace it with the correct size. If it is the right restrictor, check the pipe for proper connections and for termination blockage. • Review the flue run. If the size of the restrictor in the unit is incorrect, replace it with the correct size. If it is the right restrictor, replace it with a bigger one.
The flame is jumping from the burner.	Too much draw in the fireplace.	Review the flue run. If the size of the restrictor in the unit is incorrect, replace it with the correct size. If it is the right restrictor, replace it with a bigger one.
Part of the burner is not turning on.	<ul style="list-style-type: none"> • Too much CO in the fireplace, due to CO back feeding or an unapproved flue run. • Too much media. • Burner ports are clogged. 	<ul style="list-style-type: none"> • Review the flue run. If the size of the restrictor in the unit is incorrect, replace it with the correct size. If it is the right restrictor, check the pipe for proper connection. • Remove some of the media. No more than 70% of the burner and grill surface area should be covered. • Check burner ports for blockage.
The flame is small.	Unit manifold pressure is incorrect.	Set the correct pressure.



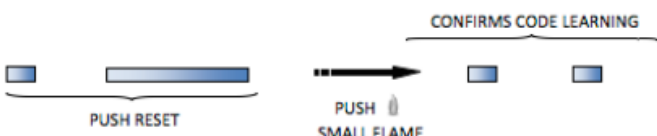

Troubleshooting Beeping

BEEPS 2008 ELECTRONIC

CONFIRMATION OF A VALID SIGNAL also Reset, new Batteries	
FAILURE: Microswitch defect ON-OFF Switch open WIRING NOT COMPLETED LEARN FUNCTION FAILED	
LOW BATTERY (During the motor turns)	
SYMBOL FOR IGNITION SEQUENCE	
LEARNING FUNCTION	 <p>PUSH RESET → PUSH  SMALL FLAME → CONFIRMS CODE LEARNING</p>





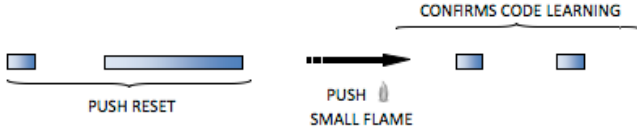

BEEPS 2010 ELECTRONIC

CONFIRMATION OF A VALID SIGNAL also Reset, new Batteries	
FAILURE: Micro switch defect ON-OFF Switch open WIRING NOT COMPLETED LEARN FUNCTION FAILED	
LOW BATTERY (During the motor turns)	
SYMBOL FOR IGNITION SEQUENCE	
LEARNING FUNCTION	

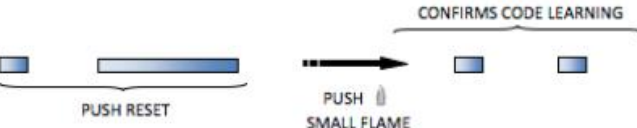

BEEPS 2013 ELECTRONIC (B6R...)

CONFIRMATION IGNITION START	
FAILURE: Micro switch defect ON-OFF Switch open WIRING NOT COMPLETED LEARN FUNCTION FAILED 2 nd THERMOCOUPLE CONNECTED TO STANDARD VERSIONS (WHITE STICKER ON THE RECEIVER'S BACKSIDE) NO 2 nd THERMOCOUPLE CONNECTED TO 2 nd THERMOCOUPLE VERSION (YELLOW STICKER ON THE RECEIVER'S BACKSIDE) IGNITION TRIED WHILE 2 nd THERMOCOUPLE HAS NOT COOLED DOWN YET	
LOW BATTERY (During the motor turns)	
RESET also Batteries changed, Power on	
LEARNING FUNCTION	



SILVER STICKER AT THIS POSITION IS USED FOR B6R VERSIONS (G6R has the sticker at a different position)

Mertik Maxitrol External Source Operation

The following figure is taken from the Mertik Maxitrol guide.

MERTIK MAXITROL[®]

gV60 Remote electronic ignition and Control system external source operation



Contact Options/Operation

FOR OEM USE ONLY

⚠ WARNING

Fire or explosion hazard. Attempted disassembly or re-pair of controls can cause property damage, severe injury or death. Do not disassemble the gas valve; it contains no serviceable components.

Read these instructions carefully and completely before installing or operating. Failure to follow them could result in a fire or explosion causing property damage, personal injury, or loss of life. Service and installation must be performed by a trained/ experienced service technician. The Mertik Maxitrol product should not be operated until it has been inspected and approved by the local code authority.

What to do if you smell gas:

- Do not operate any appliance.
- Do not touch any electrical switch; do not use any phone in your building.
- Immediately evacuate the area and contact the gas supplier. Follow the gas supplier's instructions.
- If you cannot reach the gas supplier, call the fire department.

Do NOT use this product if you suspect it has been subjected to high temperatures, damaged, tampered with, or taken apart.

Do NOT use a product if you suspect it has been under water or that liquid has seeped into the product. Any of these incidents can cause leakage or other damage that may affect proper operation and cause potentially dangerous combustion problems.

Do not store or use gasoline or other flammable vapors and liquids near this control or other appliances.

Use only your hand to push in or turn the gas control knobs. Never use tools. If a knob will not push in or turn by hand, do NOT try to repair it. Call a qualified service technician. Force or attempted repair can result in a fire or explosion.

Description

The GV60 will operate through an external source, such as a home automation system, by using the 5-wire pin connector on the receiver. A 1000 mm cable with Alex 2510-Z connector (part number G60-ZCE/1000) is available. The overall length of the cable should not exceed 8 m. Signal relays (gold contacts) or opto-couplers are recommended.

⚠ WARNING

It is the appliance manufacturer's responsibility to fully disclose any operation from a remote source that will create an unsafe operating condition. For Europe see GADAC guidance sheet B12.

Contacts Options/Operation

- **Ignition:** Close contact 1 and 3 simultaneously for 1 second.
- **Fireplace automatically goes to high after ignition sequence.**
- **UP FLAME:** Close contact 1. The contact needs to be closed for 12 seconds to turn the motor from end-stop to end-stop.
- **DOWN FLAME:** Close contact 3. The contact needs to be closed for 12 seconds to turn the motor from end-stop to end-stop.
- **Off:** Close contacts 1, 2, and 3 simultaneously for 1 second.

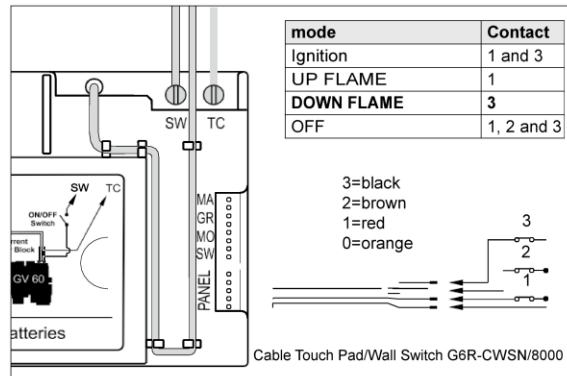

Figure 1: Wiring diagram and the operation sequence

Possible modes of Operation

Mode 1

The external source provides ON and OFF operation only. The Timer/Thermostat handset provides all other functions.

NOTICE

The Timer/Thermostat handset in Thermostatic Mode controls the room temperature even if the fire is turned on by the external source. If the handset is in Manual Mode, the fire will go to High Fire in the next cycle of external operation.

Mode 2

The external source controls the room temperature. The Timer/Thermostat handset must be set to Manual Mode (or use a standard handset). If the Timer/Thermostat handset is set to Thermostatic Mode, it will override the external source.

NOTICE

Frequent ON/OFF cycles will limit the life expectancy of the valve and will increase the battery consumption. The AC Mains Adapter may be used instead of batteries.

Appendix E: ORTAL Factory Recommended Service Checklist

Model Type: _____ Serial #: _____ Date: _____

Before, during and after service, if there is any doubt, stop and call ORTAL.

*If there is any NO answer, close the gas valve and correct.
If you cannot correct, discontinue operation, lockout unit and call ORTAL.*

1. Outside horizontal/vertical cap. Clean and unobstructed. () Yes () No
 2. Check the louver/Cavity heat release. Clean and unobstructed. () Yes () No
 3. Is there an access panel for valve and receiver maintenance? () Yes () No
 - a) Clean and unobstructed? () Yes () No
 - b) Allows access to components? () Yes () No
 4. LPG only:
Is there adequate opening for releasing a potential gas leak at the lowest point of elevation in the Cavity? () Yes () No
 5. Is glass complete and NOT broken? () Yes () No
 6. Is area around the fireplace free of wall crack or signs of heat impact? () Yes () No
Make sure the shut-off valve is in the ON position and there is gas flow. () Yes () No
 7. Verify that there is NO gas leak. () Yes () No
 8. Turn on the fireplace for visual inspection (30 sec- 1 minute).
 - a) Check if the system sparks. () Yes () No
 - b) Check if the pilot turns on. () Yes () No
 - c) Check if the burner turns on. () Yes () No
 - d) Measure gas pressure. Inlet _____ kPA. Manifold _____ kPA.
 9. Let the glass cool down.
 10. Remove glass.
 - a) Clean the glass.
 - b) Remove the media and clean / vacuum the burner. () Yes () No
 - c) Return media per installation guidelines. () Yes () No
 - d) Make sure pilot, spark plug and thermocouple area is clear. () Yes () No
 11. Check explosion valve
 - a) Push explosion valve open.
 - b) Release explosion valve to close. Is the explosion valve closed? () Yes () No
 - c) Is the explosion valve unobstructed? () Yes () No
 12. Turn unit on without the glass installed to verify the following:
Block the flame from the pilot to the thermocouple with a metal or similar divider, and verify that the main burner turns off. () Yes () No
 13. Reinstall the glass.
 14. Check silicon on the glass. If broken, flip glass to the other edge. If the other edge is also broken, apply new silicon and cure for 24 hours.
Tell owner not to turn unit on for 24 hours, until: Date: _____ Time _____
-

ORTAL Product Service Log

Product Name/ Model Type: _____
Serial Number: _____ Date of Service: _____

Location Information

Name: _____

Address: _____

City, State, Zip: _____

Is this unit installed in a Commercial/Public space or Residential? _____

Service call: () Routine or () special request. If requested, why? _____

Service Technician

Installation Technician Name: _____

NFI Gas Specialist ID #: _____

Technician Company Name: _____

Technician Signature and date: _____

Customer Company Name: _____

Fireplace Customer/Owner

Customer Individual Name: _____

Customer Signature and date: _____

A copy of this service record to remain with the fireplace unit and Owner.

A copy of this service record to remain with the service technician.

If any product or warranty concerns are present or replacement parts are required please provide a copy of the complete service record to:

**ORTAL HEATING SOLUTIONS LTD.
SERVICE DEPT.
14 HAHARASH ST.
HOD HASHARON, ISRAEL
FAX: +972-9-7402687
e-mail: qa@ortal-heat.com**

Appendix F: Warranty Policy

Below is the warranty policy of Ortal Ltd for Standard products sold and distributed in Australia & New Zealand. Warranties may vary for custom models.

THE WARRANTY

The Ortal Ltd. Limited Warranty warrants your Ortal gas fireplace ("Product") to be free from defects in materials and workmanship at the time of manufacture. The Product body and firebox carry the 10 Year Limited Warranty. Ceramic glass carries the 2 Year Limited Warranty against thermal breakage only. After installation, if covered components manufactured by Ortal are found to be defective in materials or workmanship during the Limited Warranty period and while the Product remains at the site of the original installation, Ortal will, at its option, repair or replace the covered components. If repair or replacement is not commercially practical, Ortal will, at its option, refund the purchase price or wholesale price of the Ortal product, whichever is applicable. Ortal will also pay Ortal prevailing labour rates, as determined in its sole discretion, incurred in repairing or replacing such components for up to 2 years. There are exclusions and limitations to this limited warranty as described herein.

COVERAGE COMMENCEMENT DATE

Warranty coverage begins on the date that the fireplace shipped from Oblica's warehouse.

EXCLUSIONS AND LIMITATIONS

This Limited Warranty applies only if the Product is installed in the Australia and/or New Zealand and only if installed, operated and maintained in accordance with the printed instructions accompanying the Product and in compliance with all applicable installation and building codes and good trade practices. Printed instructions include those, which direct the installer and/or owner to refer to the product information, diagrams, and operation and maintenance manuals available on Ortal's website, www.ortalheat.com. These can also be requested in digital format direct from Ortal's office(s).

This warranty is non-transferable and extends to the original owner only. The Product must be purchased through a listed supplier of Ortal and proof of purchase must be provided. The Product body and firebox carry the 10 Year Limited Warranty from the date of installation. Flue components, trim components and paint are excluded from this Limited Warranty. The following components are part of the Limited Warranty and are warranted as follows:

- Burner:** Repair or replacement - two years coverage.
- Gas Components (including the valve):** Repair or replacement - two years.
- Interior Decorative Media:** Replacement for one year from the date of installation against thermal breakage only
- Electrical components and Remote Controls:** Repair or replacement - two years. Water damage and batteries are entirely excluded.
- Ceramic Glass:** Replacement for two years against thermal breakage only.
- Labour Coverage:** Prevailing Ortal labour rates apply for the warranty period of components. Labour coverage is for actual repair and/or replacement of components. Troubleshooting is excluded.

Parts not otherwise listed carry a 90-day warranty from the date of installation.

Whenever practicable, Ortal will provide replacement parts, if available, for a period of 2 years from the last date of manufacture of the Product.

Ortal will not be responsible for: (a) damages caused by normal wear and tear, accident, riot, fire, flood, climate and weather corrosion or natural disaster; (b) damages caused by abuse, negligence, misuse, or unauthorized alternation or repair of the Product affecting its stability or performance. The Product must be subjected to normal use. The Product is designed to burn on either natural or propane gas only as determined by the costumer when originally purchased or changed after installation by an authorized installer only. Burning conventional fuels such as wood, coal or any other solid fuel will cause damage to the Product, will produce excessive temperatures and could result in a fire hazard.; (c) damages caused by failing to provide proper maintenance and service in accordance with the instructions provided with the Product; (d) damages, repairs or inefficiency resulting from faulty installation or application of the Product.

Ortal is not responsible for inadequate fireplace system draft caused by air conditioning and heating systems, mechanical ventilation systems, or general construction conditions which may generate negative pressure in the room in which the appliance is installed. Additionally, Ortal assumes no responsibility for drafting conditions caused by flueing configurations, adjoining trees or buildings, adverse wind conditions or unusual environmental factors and conditions that affect the operation of the unit.

This Limited Warranty covers only parts and labour as provided herein. In no case shall Ortal be responsible for materials, components or construction, which are not manufactured or supplied by Ortal or for the labour necessary to install, repair or remove such materials, components or construction. Additional utility bills incurred due to any malfunction or defect in equipment are not covered by this warranty. All replacement or repair components will be shipped F.O.B. from the nearest stocking Ortal warehouse.

LIMITATION ON LIABILITY

It is expressly agreed and understood that Ortal's sole obligation and the purchaser's exclusive remedy under this warranty, under any other warranty, expressed or implied, or in contract, tort or otherwise, shall be limited to replacement, repair, or refund, as specified herein.

In no event shall Ortal be liable for any incidental or consequential damages caused by defects in the Product, whether such damage occurs or is discovered before or after repair or replacement, and whether such damage is caused by Ortal's negligence. Ortal has not made and does not make any representation or warranty of fitness for a particular use or purpose, and there is no implied condition of fitness for a particular use or purpose.

Ortal makes no expressed warranties except as stated in the Limited Warranty. The duration of any implied warranty is limited to the duration of this expressed warranty. No one is authorized to change this Limited Warranty or to create for Ortal any other obligation or liability in connection with the Product. Some states and provinces do not allow the exclusion or limitation of incidental or consequential damages, so the above limitations or exclusions may not apply to you. The provisions of the Limited Warranty are in addition to and not a modification of or subtraction from any statutory warranties and other rights and remedies provided by law.

INVESTIGATION OF CLAIMS AGAINST WARRANTY

Ortal reserves the right to investigate any and all claims against this Limited Warranty and to decide, in its sole discretion, upon the method of settlement.

To receive the benefits and advantages described in this Limited Warranty, the appliance must be installed and repaired by either a qualified or authorized Ortal installation technician. Refer to your dealer/distributor sales agreement for requirements. Contact Ortal at the address provided herein to obtain a listing of approved dealers/distributors and certified/authorized installer companies.

Ortal shall in no event be responsible for any warranty work done by an installer that is not approved without first obtaining Ortal's prior written consent.

HOW TO REGISTER A CLAIM AGAINST WARRANTY?

In order for any claim under this warranty to be valid, you must contact the Ortal dealer/distributor from which you purchased the product. If you cannot locate the dealer/distributor, then you must notify Ortal in writing. Submission of a completed warranty claim is the preferred method of warranty claim notification. Ortal must be notified of the claimed defect in writing within 90 days of the date of failure. Notices should be directed to the Ortal Warranty Department or visit our website at www.ortalheat.com/

Printed in Israel. © 2024 Ortal Ltd.

Manufacturer Contact Information

For all service issues, please contact your local dealer.

**ORTAL HEATING SOLUTIONS LTD.
SERVICE DEPT.
14 HAHARASH ST.
HOD HASHARON, ISRAEL
FAX: +972-9-7402687
e-mail: qa@ortal-heat.com**

Installer

Company Name: _____

Technician Name: _____

Address: _____

Tel: _____

Fax: _____

E-mail: _____

Website: _____

© Ortal 2024
Ver. 1.8 May 2024
KPMANWILDAUV1.8